



## BUTTERFLY VALVE

## ME SERIES

27/04/2012

### BI-ECCENTRIC Butterfly Valve

- Unidirectional butterfly valve with double eccentricity.
- Various construction materials available.
- Two options for width over flats:
  - Short series: in accordance with Standard EN 558 SERIES 13.
  - Long series: in accordance with Standard EN 558 SERIES 14.
- It has an arrow on the body indicating the flow direction.

#### General applications:

- This butterfly valve is suitable for working in line and as a safety valve in emergency cases. It is widely used in pressure pipes in hydroelectric plants.

#### Sizes:

DN200 to DN3000 (larger sizes to order).

#### Working ( $\Delta P$ ):

The differential pressure ( $\Delta P$ ) these valves can work at is very variable; they are designed for the specific needs of each project, but can be designed to withstand pressures of up to 100 kg/cm<sup>2</sup>.

#### Fluid speed:

The maximum fluid speed these valves can work at is 4.9 m/s (in accordance with Standard AWWA C 504).

#### Flange drill hole:

DIN PN10 and ANSI B16.5 (150 LB)

#### Others commonly used:

DIN PN 16	JIS standard	Australian Standard
DIN PN 6	DIN PN25	British Standard

#### Directives:

- Machinery Directive: **DIR 2006/42/EC (MACHINERY)**
- Pressure Equipment Directive: **DIR 97/23/EC (PED) ART.3, P.3**

#### Quality dossier:

- All valves are hydrostatically tested with water at CMO and material certificates (in accordance with Standard EN 10204 3.1.) and test certificates (in accordance with Standards ISO 5208 and EN 12266) are supplied.
- Body test = working pressure x 1.5.
- Seal test = working pressure x 1.1.

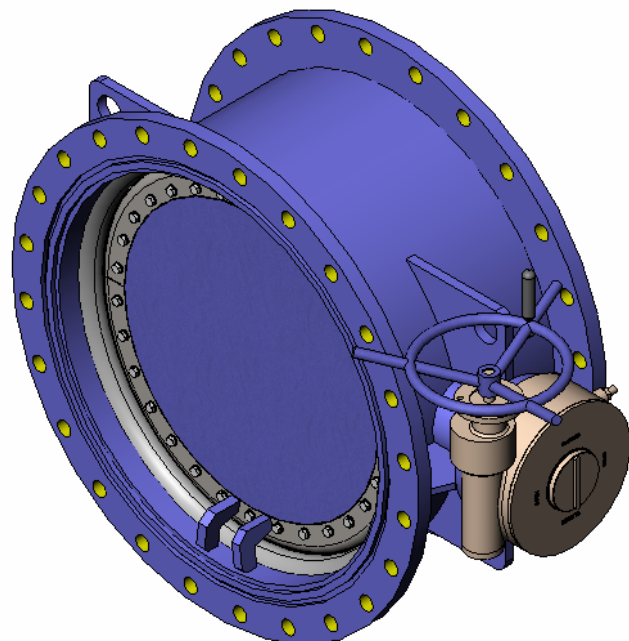

fig.1



## BUTTERFLY VALVE

## ME SERIES

### Advantages of CMO's "ME Model"

The main characteristic of CMO's **ME** butterfly valve is the double eccentric design.

The rotation shaft is offset from the central plane of the clapper (Exc.1), and in turn is also offset from the central plane of the valve body (Exc.2), thus obtaining double eccentricity (Fig. 2).

A highly effective sealing system is achieved thanks to this double eccentricity. As soon as the valve starts to open, the elastomer seal is no longer pressed and does not come into contact with the body. For this reason the seal is not pressed until the moment of sealing, thus avoiding any contact and extending its working life.

Furthermore, since the rotation shaft is offset from the central plane of the body (Exc.2), the flow always tends to shut off the valve; this is a big advantage when the valve operates as a safety valve in emergency situations.

The **ME** valve body consists basically of a shell of the same interior diameter as the duct where it is installed, with a flange on each side. These flanges have a machined recess in order to position the O-ring; thanks to these O-rings no additional seal is required in order to mount the valve between flanges. In order to make the seal, there is a machined stainless steel ring inside the shell, providing an efficient seal with minimum disturbance to the flow.

The valve is, thanks to these characteristics and its simplicity, both robust and economical, highly suited for working in both inputs and discharges.

However, these valves are not suitable for regulating flow. When the valve is completely open, the clapper is in horizontal position, meaning the disc is parallel to flow direction and the disturbances generated by the valve in the flow are minimal. Smaller degrees of opening translate to greater disturbances in the flow, since the clapper is more vertical and greater vibrations and turbulence is generated.

We do not recommend using this type of valve with intermediate openings, since they are not suitable for regulating flow.

These valves are highly suited for use in emergency situations, since they are usually completely open, generating minimum disturbance in the flow; moreover, whenever an emergency situation comes about, they shut off quickly, thus avoiding medium degrees of opening.

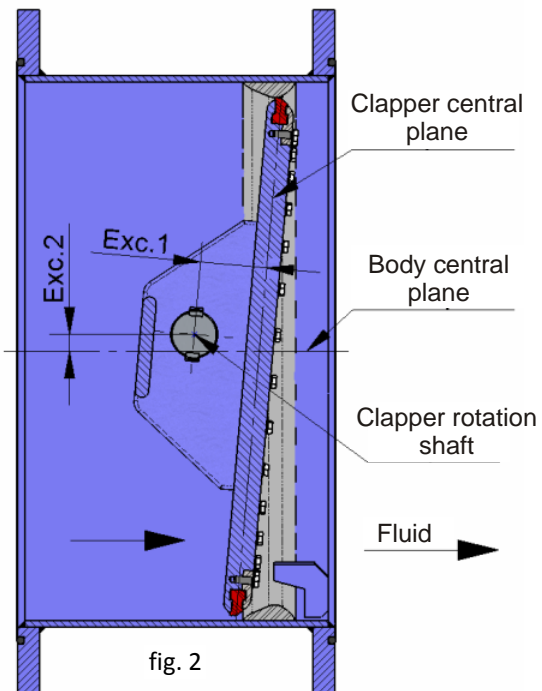



BUTTERFLY VALVE

ME SERIES

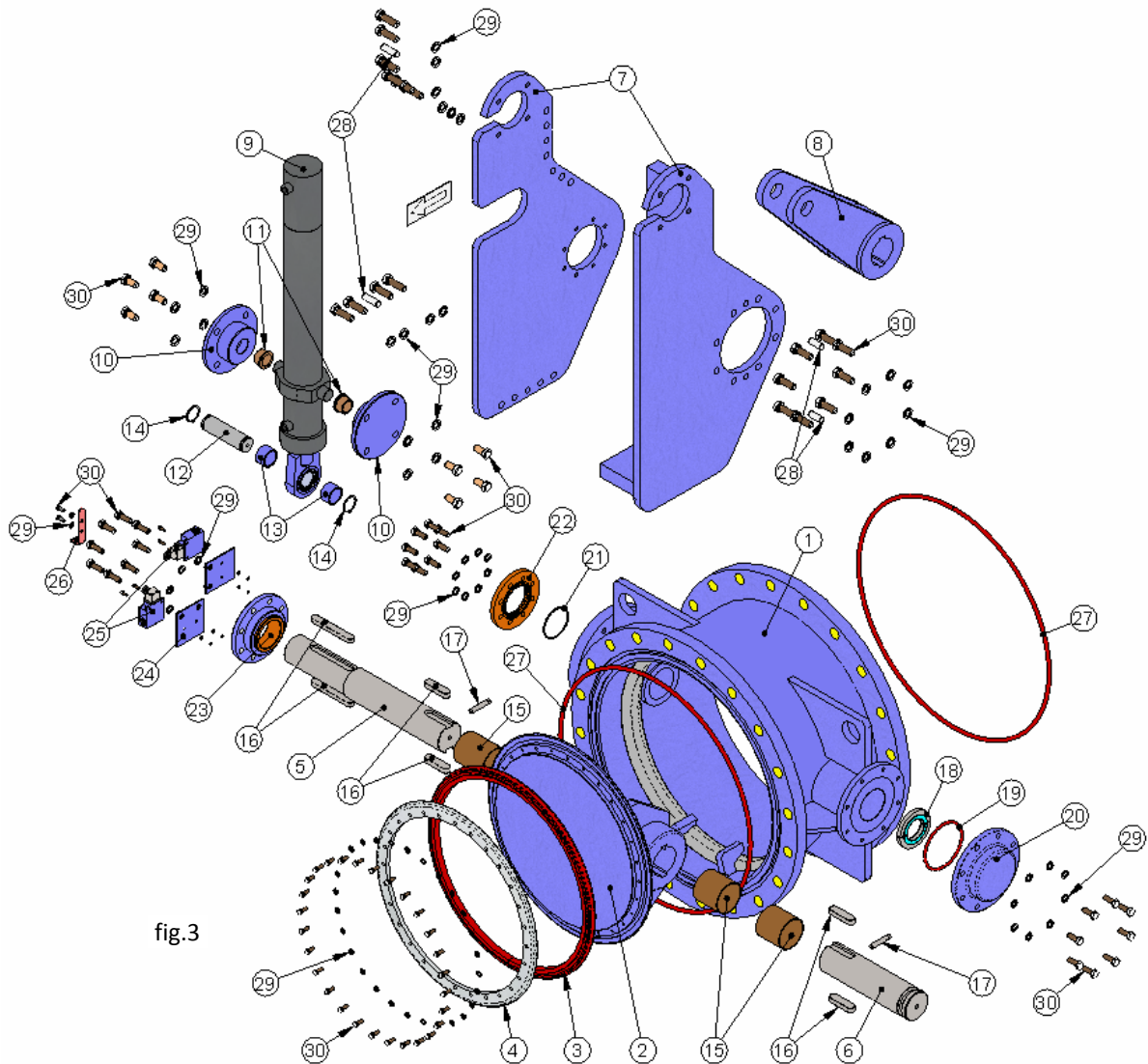

STANDARD COMPONENTS LIST			
POS.	COMPONENT	POS.	COMPONENT
1	BODY	16	COTTER
2	CLAPPER	17	PIN
3	SEAL	18	FRICTION WASHER
4	FLANGE SEAL	19	RUBBER RING
5	DRIVE SHAFT	20	SOLID COVER
6	SHAFT	21	RUBBER RING
7	ACTUATOR SUPPORT	22	GUIDE COVER
8	ACTUATOR ARM	23	SUPPORT COVER
9	ACTUATOR	24	LIMIT SWITCH SUPPORT
10	SUPPORT COVER	25	LIMIT SWITCH
11	BUSH BEARING	26	POSITION INDICATOR
12	PIN	27	O-RING SEAL
13	DISTANCER BUSHING	28	PIN
14	CIR-CLIP	29	WASHER
15	BUSH BEARING	30	SCREW

table 1

C.M.O.



## BUTTERFLY VALVE

## ME SERIES

### DESIGN CHARACTERISTICS

#### 1- BODY

The **ME** valve body consists basically of a shell of the same interior diameter as the duct where it is installed, with a flange on each side. These flanges have a machined recess throughout the diameter in order to position the O-ring.

There is a ring inside the shell in order to make the seal; this ring is always stainless steel, regardless of the material of the body. This ring is then machined for efficient sealing and minimum disturbances in the flow.

In order to house the shafts, hubs are positioned on the body shell, with reinforcements and ribs on the outside to join the housings for the shafts, shell and flanges. This achieves a highly robust single-piece body which can withstand any level of tension.

The standard manufacturing materials are S275JR carbon steel, GGG50 and AISI304 or AISI316 stainless steel. However, other stainless steel alloys and materials (AISI316Ti, Duplex, 254SMO, Uranus B6, etc) are available on request.

As standard, carbon steel bodies are painted with an anti-corrosive EPOXY protection (colour RAL 5015). Other types of anti-corrosive protections are available to order.

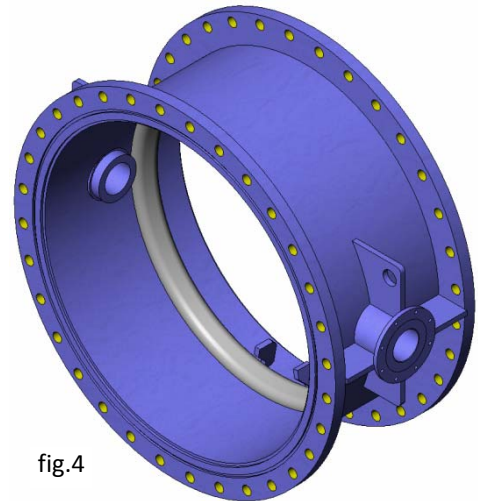

fig.4

#### 2- CLAPPER

The clapper consists basically of a very thick, flat circular disc. This disc has two lugs in order to couple the shafts and transmit the movement of the actuator (fig. 5). The clapper is sized in line with working pressure. CMO clappers are always moved by cotters and not by pins.

The standard manufacturing materials are S275JR carbon steel in valves with S275JR carbon steel body, GGG50 nodular cast in valves with GGG50 body and AISI304 or AISI316 stainless steel in valves with AISI304 or AISI316 body respectively. Other materials or combinations can be supplied to order.

The clapper has a machined recess throughout the perimeter of the main disc, housing the seal tight joint which is secured by way of the flange.

As standard, carbon steel clappers are painted with an anti-corrosive EPOXY protection (colour RAL 5015). Other types of anti-corrosive protections are available to order.

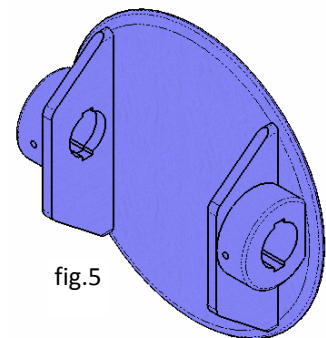

fig.5

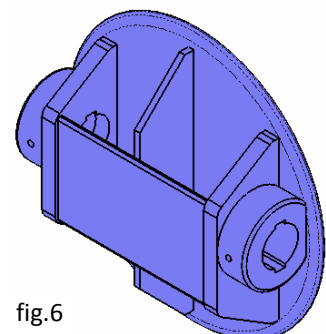

fig.6



## BUTTERFLY VALVE

## ME SERIES

### 3 - SEAT/SEAL:

CMO's **ME** butterfly valves make the seal by pressing the special elastomer profile (3) against a stainless steel ring (5).

The special elastomer profile (3) is located in the outer recess of the perimeter of the clapper (2) and is secured by way of a flange (4) with stainless steel screws (6).

The stainless steel ring (5) is located inside the body shell (1), and has been machined in order to ensure correct sealing and minimise disturbances in the flow.

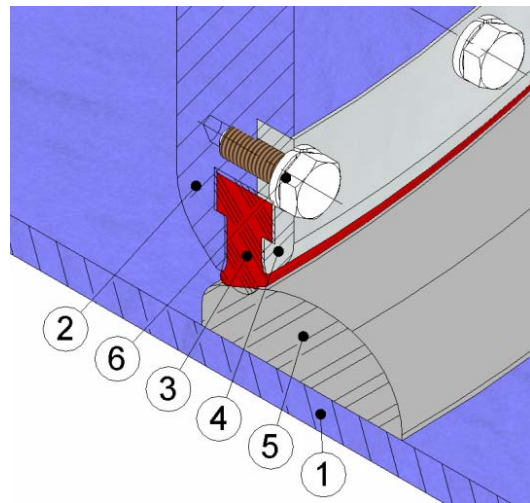

fig.7

Seal tightness is usually achieved with an EPDM seal, although other types of elastomers are available.

The seal can be changed without removing the valve from the pipeline.

### Seal tight materials

#### EPDM

This is the standard resilient seal fitted on CMO valves. It can be used in many applications, although it is generally used for water and products diluted in water at temperatures no higher than 90°C. It can also be used with abrasive products and provides the valve with 100% seal-tightness.

#### NITRILE

It is used in fluids containing fats or oils at temperatures no higher than 90°C. It provides the valve with 100% seal-tightness.

#### VITON

Suitable for corrosive applications and high temperatures up to 190°C continuously and peaks of 210°C. It provides the valve with 100% seal-tightness.

#### SILICONE

Used mainly in the food industry and for pharmaceutical products with temperatures no higher than 200°C. It provides the valve with seal-tightness of 100%.

**Note:** In some applications other types of rubber are used, such as hypalon, butyl or natural rubber. Please contact CMO if you require one of these materials.

SEAT/SEALS		
Material	Max temp (°C)	Applications
EPDM (E)	90 *	Non-mineral oils, acids and water.
Nitrile (N)	90 *	Hydrocarbons, oils and greases
Viton (V)	200	Hydrocarbons and solvents
Silicone (S)	200	Food Products

NOTE: More details and other materials available to order. \* → EPDM and Nitrile: possible up to max temp.: 120°C to order.

table 2



## BUTTERFLY VALVE

## ME SERIES

### 4- SHAFTS

The shafts of (3) CMO's **ME** butterfly valves are made from AISI316, AISI420, etc, stainless steel, making them highly resistant with excellent properties in preventing corrosion.

Parallel cotters (4) are used to transmit the movement of the actuator to the clapper, meaning both the clapper (2) and the shafts (3) have several machined cotter holes.

Self-lubricating bronze bushing (5) is placed in the body hubs (1) in order for the shafts (3) to turn easily.

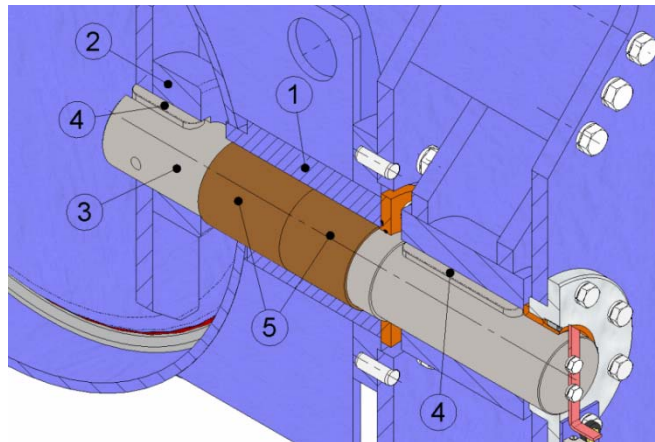

fig.8

### 5- O-RING SEALS

O-rings are used to guarantee seal tightness between the duct and the outside (4). The only points in which there may be leakages from the body are between the shafts (2) and the hubs (1), meaning seal tightness is achieved by placing O-rings (4) in a bronze flange (3). The O-rings (4) used in the **ME** valves are usually nitrile, although other types of elastomers are available.

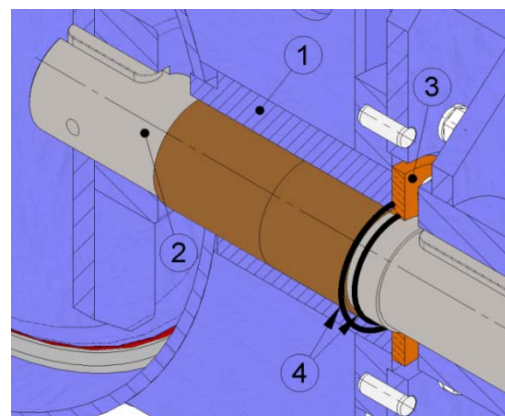

fig.9

### 7- ACTUATORS

All types of actuators can be supplied, whether manual or automatic. The most suitable type of actuator will be chosen in each case in accordance with the working conditions and characteristics of the facility. Sometimes it is the customer who specifies what type of actuator is required for the project.

#### Manual:

Geared motor

#### Automatic:

Electric actuator  
Hydraulic cylinder

#### Wide range of accessories available:

Mechanical stoppers  
Locking devices  
Emergency counterweight actuators  
Positioners  
Limit switches  
Proximity detectors

...



# BUTTERFLY VALVE

# ME SERIES

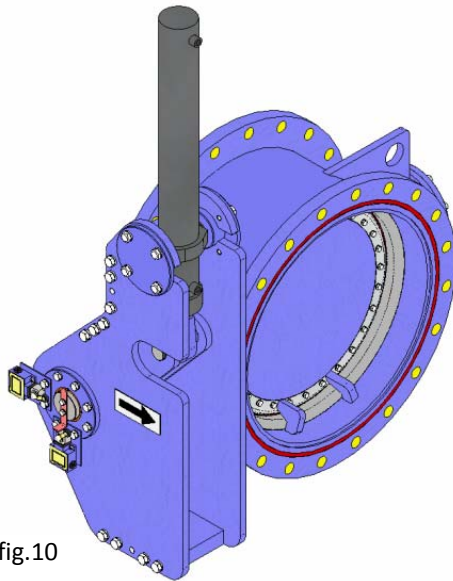

fig.10

Double-Acting Hydraulic  
Actuator

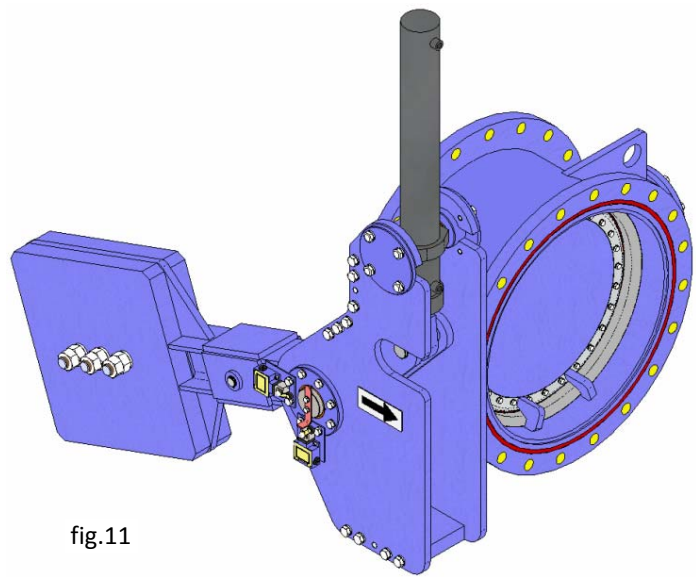

fig.11

Hydraulic Actuator +  
Counterweight

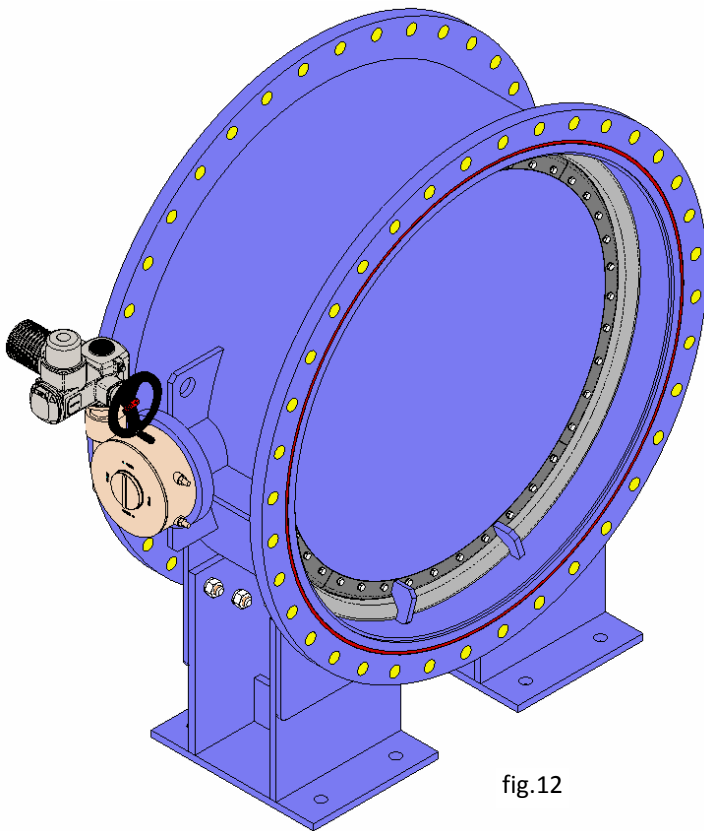

fig.12

Motorised Geared  
Actuator

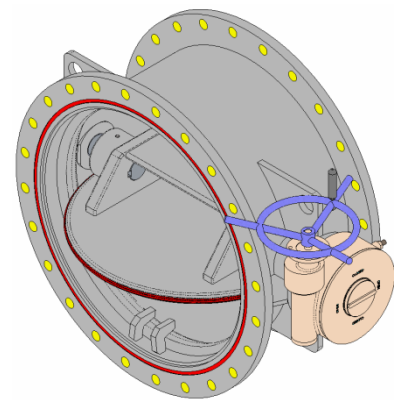

fig.13

Manual Geared  
Actuator



## BUTTERFLY VALVE

## ME SERIES

### ACCESSORIES AND OPTIONS

Different accessories are available to adapt the valve to specific working conditions such as:

**Connection boxes, wiring and hydraulic piping:**

Units supplied fully assembled with all the necessary accessories.

**Mechanical limit switches or inductive sensors (fig. 14):**

An arrow is coupled to the end of one of the shafts in order to indicate the valve opening position; this indication arrow enables the mechanical limit switches, which indicate the position of the valve at each moment.

If the customer so requires, inductive sensors can be supplied instead of mechanical limit switches.

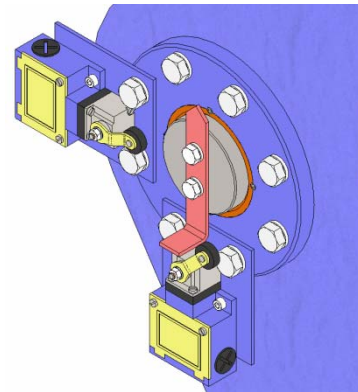
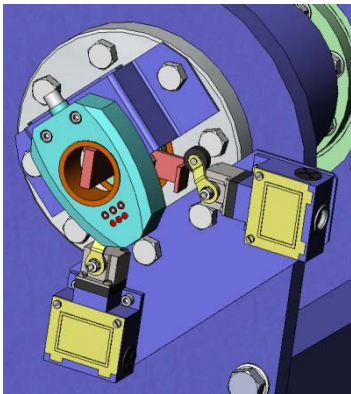

fig.14



**Positioners (fig. 15):**

When the position of the valve is to be known remotely, a positioner is installed to indicate the position of the valve continuously.

fig.15

**Mechanical locking system (fig. 16):**

Allows the valve to be mechanically locked in a set position for long periods.

fig.16

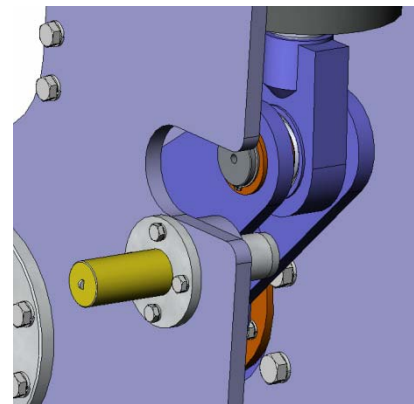

**Stroke limiting mechanical stops:**

These allow the degree of opening of the valve to be mechanically adjusted, limiting the required turning travel for the clapper.

**Emergency actuator (wheel / counterweight):**

When the valve is fitted with an automatic actuator (motorised or hydraulic), the emergency actuator allows the butterfly valve to operate in the event of a power failure.

- Hydraulic actuator (fig. 11): When the valve is fitted with a hydraulic cylinder as the actuator, there is the option of adding a counterweight. In the event of failure in the hydraulic circuit, this counterweight would tend to shut off the valve, whilst the hydraulic cylinder would act as an absorber, allowing the sealing speed to be controlled from the starter valve. It can therefore be adjusted for gentle sealing without water hammer effect.

- Motorised actuator (fig. 12): All motorised actuators supplied by CMO have a declutchable emergency wheel in order to operate the valve manually in the event of a power failure.





## BUTTERFLY VALVE

## ME SERIES

### Epoxy coating:

All carbon steel components and bodies of **CMO** valves are EPOXY coated, giving the valves great resistance to corrosion and an excellent surface finish. **CMO's** standard colour is blue RAL-5015.

### Safety guards (fig. 17):

In accordance with European Safety Standards ("EC" marking), **CMO's** automated valves are equipped with metal guards for the travel of the rod and counterweight (when fitted), thus preventing any object or body from being accidentally caught or dragged.

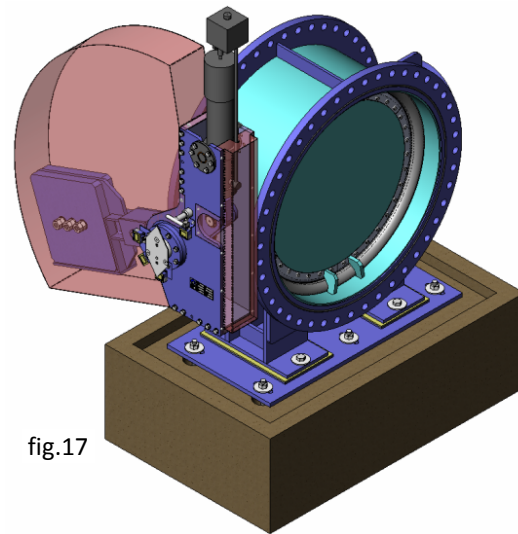

fig.17

## VARIANTS OF BUTTERFLY VALVES

There are two main variants based on these **ME** butterfly valves.

### A. COMBINATION OF BUTTERFLY AND RETENTION VALVE (fig. 18):

This type of valve is a butterfly valve which acts as a retention valve, with the peculiarity that it allows the level of opening of the valve to be defined.

This valve is permanently shut off, opening only due to the force of the flow, up to the opening level defined at each moment.

The eccentricity between the rotation shaft and the central plane of the body (Exc. 2 in fig. 2) is greater than that commonly found in a butterfly valve and is similar to that found in a retention valve, making it easier for the flow to open the clapper.

One of the valve shafts has been specially machined in order to couple a motorised geared motor. This carries out the function of defining the degree of opening of the valve, even when the valve must be kept completely shut-off.

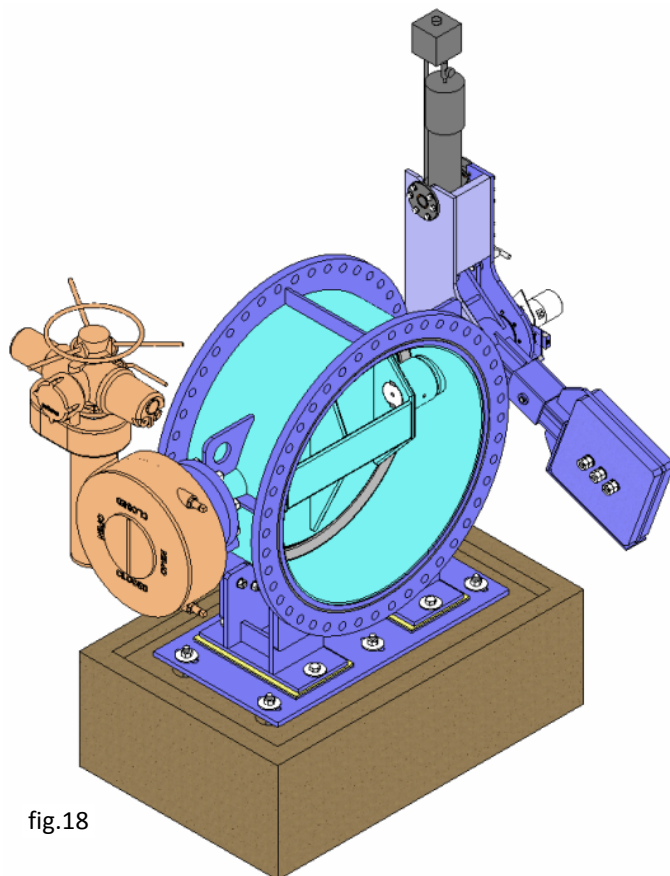

fig.18



## BUTTERFLY VALVE

## ME SERIES

A hydraulic cylinder with a counterweight is coupled to the other valve shaft. The counterweight comprises a series of screwed plates and is used to control the flow required to open the clapper; the clapper will open with more or less flow depending on the number of plates positioned in the counterweight.

A hydraulic cylinder which acts as an absorber is installed along with the counterweight. This hydraulic cylinder absorbs the movements of the clapper, depending on the flow variations. The resistance of the absorber can be regulated from the hydraulic cylinder starter valve. In the event of there being no flow in the duct, this will prevent the clapper from closing suddenly, it being possible to adjust the clapper closing speed from the starter valve.

### B. EXCESS SPEED VALVE:

This type of valve is a butterfly valve which acts as an emergency valve, comprising an **ME** butterfly valve and an excess speed detector.

These excess speed valves are installed in pipelines in which there is danger of pipe rupture. In the event of rupture in the pipe or any other cause, the excess speed detector will shut off the **ME** butterfly valve. The excess speed detector is positioned upwater from the butterfly valve, at a distance of 1.5 times the diameter of the valve with a minimum distance of 500 mm (level "X" in fig. 21 and fig. 24).

It may be electric (fig. 19) or mechanical (fig. 20), but operation is basically the same. This consists of a disc-shaped blade which is inserted in the duct, perpendicular to the direction of the flow. This blade is connected to a shaft, which has a lever with a counterweight at one of the ends. The counterweight lever is usually idle, with the counterweight arm lifting up and activating the limit switch (in the case of electrical detector, fig. 19) or hydraulic valve (in the case of mechanical detector, fig. 20) whenever the flow on the blade exceeds the weight of the counterweight.

This counterweight comprises several screwed plates, regulating the minimum flow speed required to activate the excess speed detector. The more plates positioned on the counterweight lever, the greater the flow speed required to exceed the weight of the counterweight. Another way to achieve the same effect is to distance these plates on the lever from the rotation shaft.

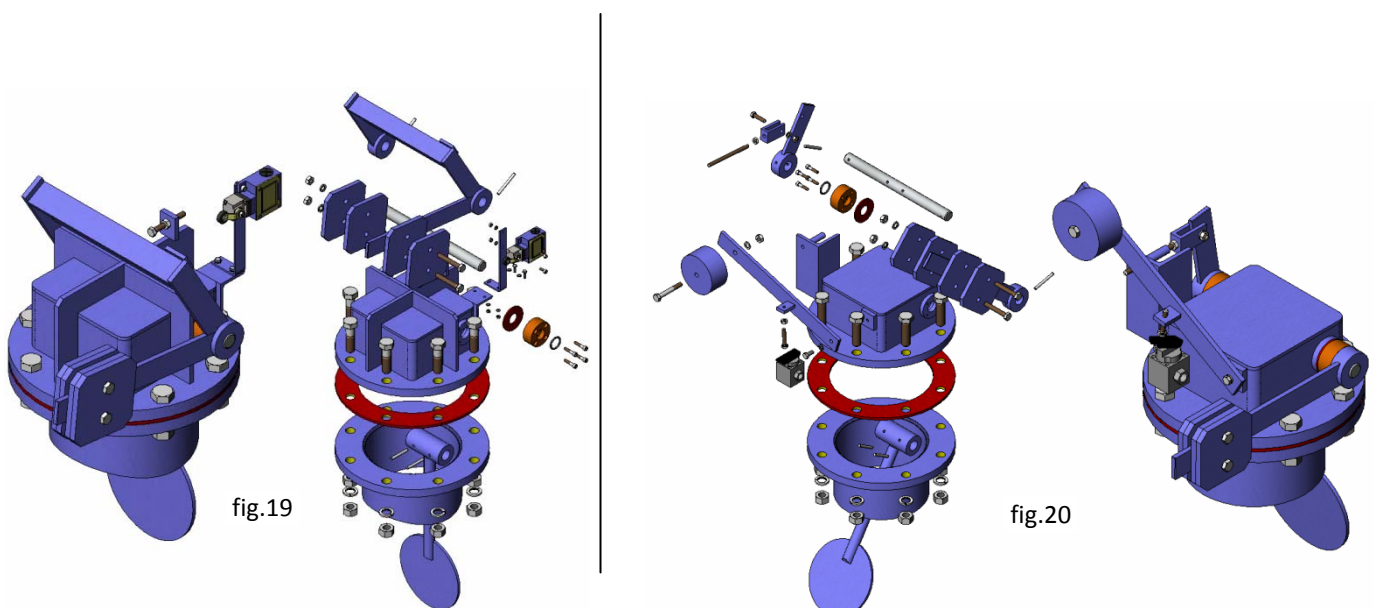



## BUTTERFLY VALVE

## ME SERIES

### ELECTRIC UNIT

This comprises an electric excess speed detector with an **ME** butterfly valve with hydraulic cylinder and counterweight. This unit is supplemented with an electrical cabinet and a motorised hydraulic fluid group which governs the unit as a whole.

When the open button is pressed in the electrical cabinet, the hydraulic fluid group starts up and activates the hydraulic cylinder, opening the valve. The flow then begins to pass at a specific speed, which is lower than that required to activate the excess speed detector (fig. 22).

In the event of rupture in the duct or any anomaly which causes an increase in the flow speed, the excess speed detector will activate the limit switch; this will send the excess speed signal to the electrical cabinet and will cut off the supply of pressurised oil to the hydraulic cylinder, which, due to the counterweight, will shut off the valve (fig. 23).

This will remain closed until the operator checks the state of the duct, or the cause of the anomaly. Once the problem has been solved, reset the electrical cabinet and open the valve.

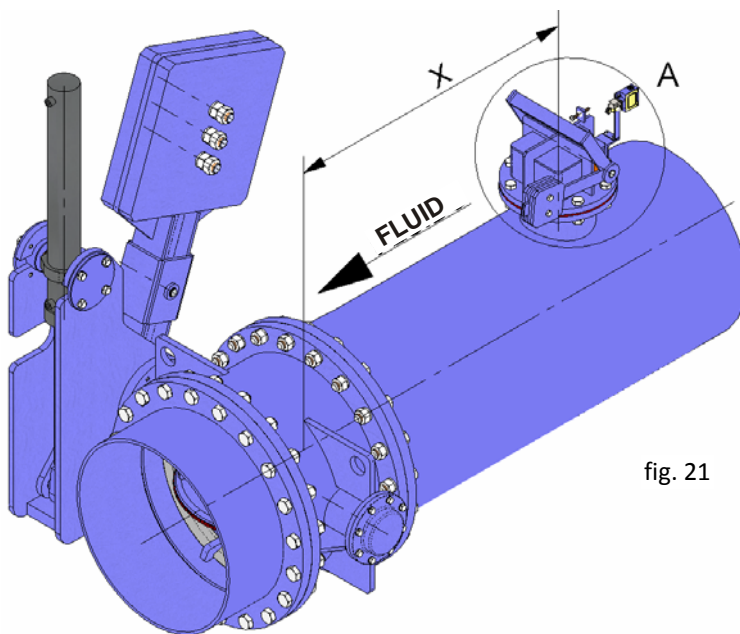
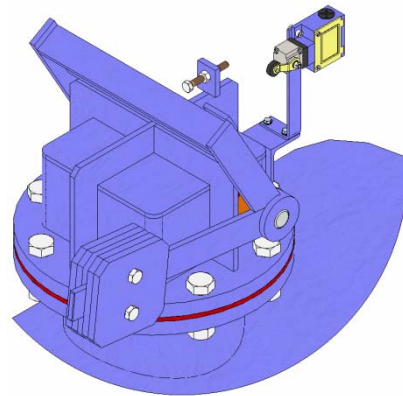

fig. 21



DETAIL A

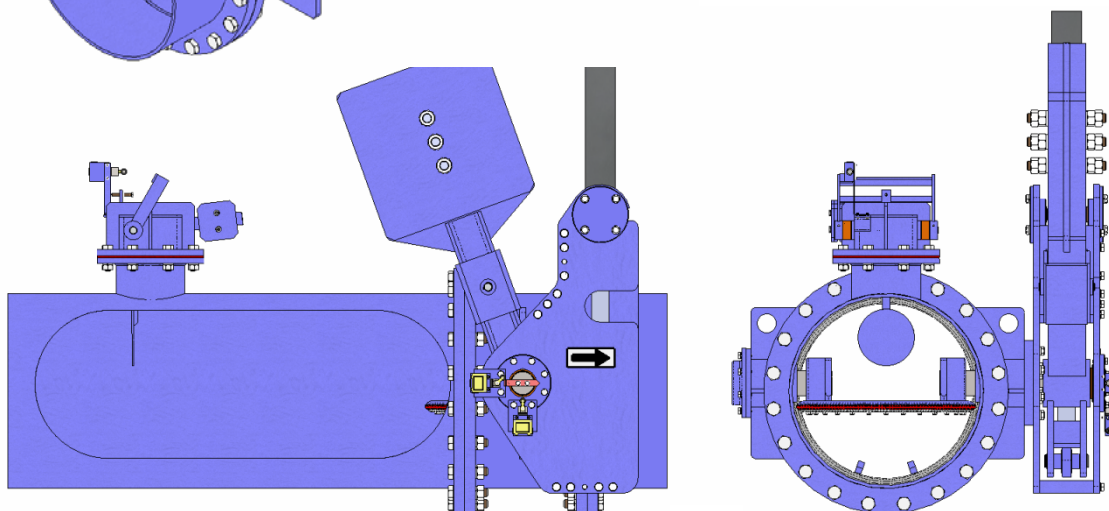

fig.22

The excess speed detector is idle → **ME** butterfly valve remains open.



## BUTTERFLY VALVE

## ME SERIES

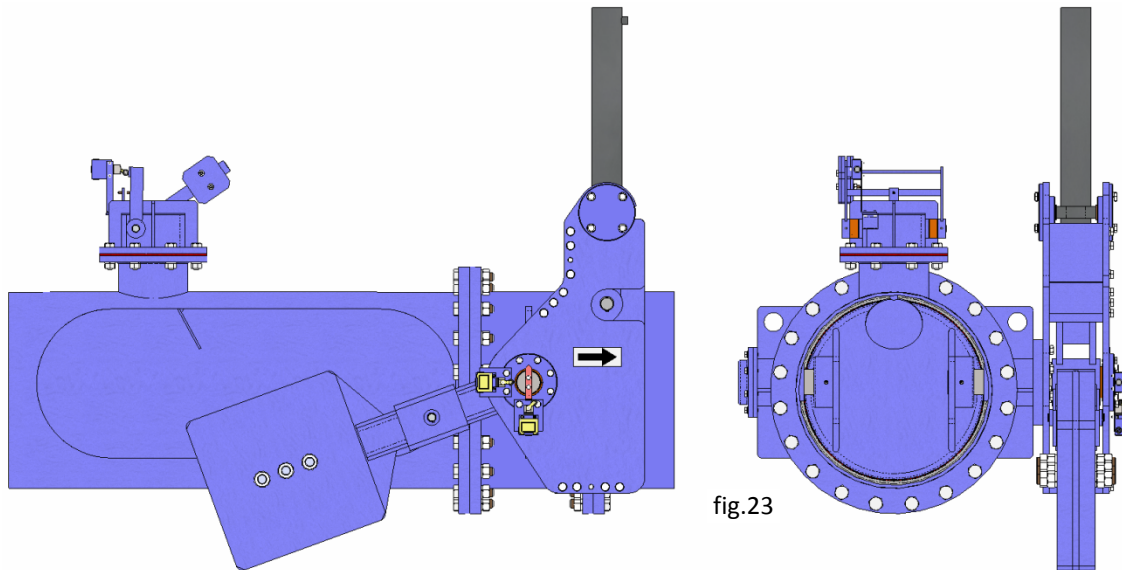

fig.23

The excess speed detector is activated by the speed of the fluid → **ME** butterfly valve shuts off.

### MECHANICAL UNIT

This comprises a mechanical excess speed detector with an **ME** butterfly valve with hydraulic cylinder and counterweight, supplemented with a manual hydraulic fluid group which governs the hydraulic cylinder.

This type of unit is ideal for installations in which there is no electricity supply.

In order to work with the **ME** butterfly valve, the first step is to open the valve, first introducing pressure in the hydraulic cylinder using the manual hydraulic fluid group.

The flow then begins to pass at a specific speed, which is lower than that required to activate the excess speed detector.

In the event of rupture in the duct or any anomaly which causes an increase in the flow speed, the excess speed detector will act on the hydraulic valve, allowing passage between the hydraulic cylinder feed pipe and the manual hydraulic fluid group, leading to a drop in pressure, with the valve shutting off due to the counterweight.

This will remain closed, even when pressure is introduced using the manual hydraulic fluid group, since the hydraulic valve of the excess speed detector remains open. Once the operator has checked the state of the duct or solved the cause of the anomaly, reset the mechanical excess speed detector and then introduce pressure in the hydraulic cylinder in order to open the butterfly valve again.

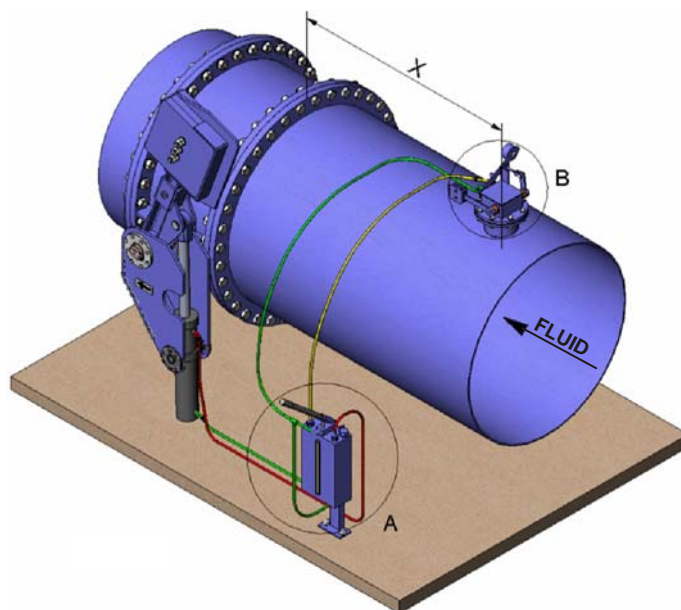

fig.24



## BUTTERFLY VALVE

## ME SERIES

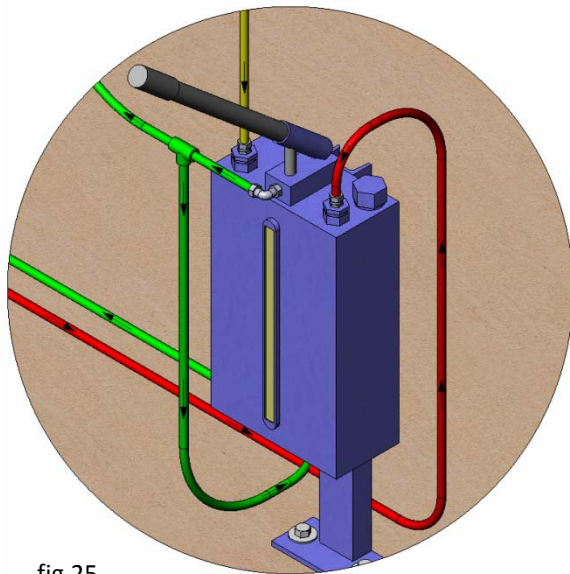

fig.25

DETAIL A

**Green piping:** Manual hydraulic fluid group output.

**Red piping:** Hydraulic cylinder return.

**Yellow piping:** Mechanical excess speed detector return.

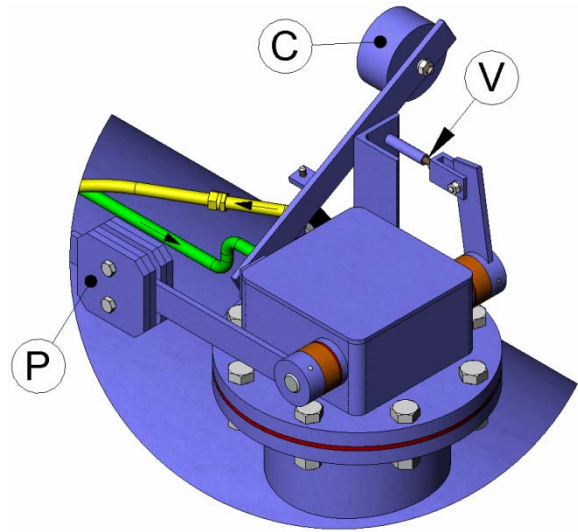

fig.26

DETAIL B

**Green piping:** Input to the hydraulic valve of the mechanical excess speed detector.

**Yellow piping:** Mechanical excess speed detector hydraulic valve output.

### Instructions to reset the mechanical excess speed detector (fig.26):

Whenever the **ME** butterfly valve shuts down due to excess fluid speed, follow these steps to reopen the valve:

- Raise the detector's "P" counterweight for the "V" rod to recede.
- Keeping the "P" counterweight raised, bring up the other "C" counterweight.
- When the "P" and "C" counterweights are raised, lower the "P" counterweight and then the "C" counterweight, supported on the "V" rod.
- It is now ready to reintroduce pressure in the hydraulic cylinder using the manual hydraulic fluid group and open the **ME** butterfly valve.

Whatever the type of excess speed detector, whether mechanical or electric, it should be installed upwater from the **ME** butterfly valve, at the distance of 1.5 times the diameter of the valve (level "X" in fig. 21 and fig. 24), provided a minimum distance of 500 mm is respected.

The **ME** butterfly valve in this type of installation is commonly for both the mechanical and electric detectors. The main feature is that the **ME** butterfly valve actuator system comprises a hydraulic cylinder and a counterweight.

The exploded view shown below (fig. 27) belongs to this type of valve.



# BUTTERFLY VALVE

# ME SERIES

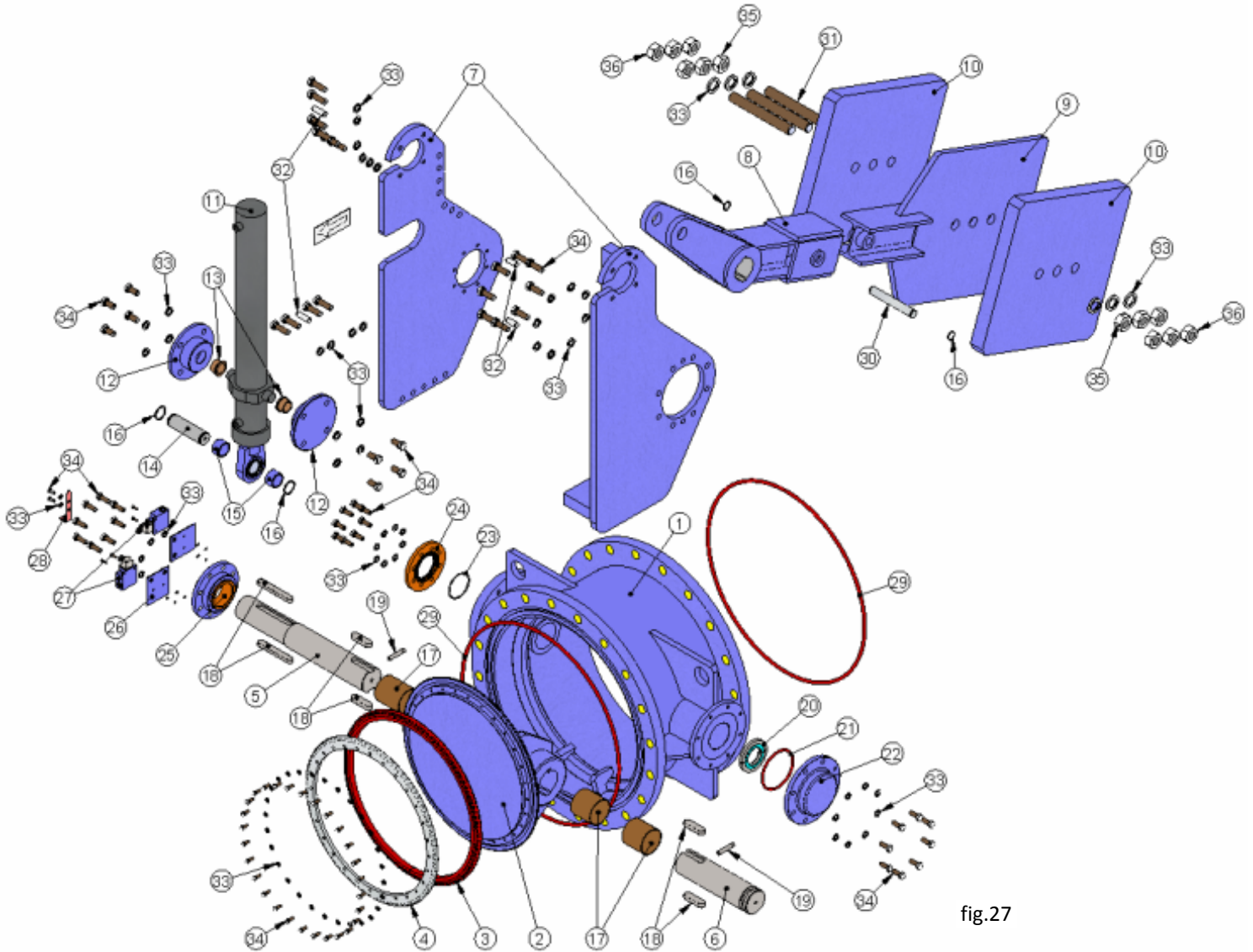

fig.27

EXCESS SPEED BUTTERFLY VALVE COMPONENTS LIST					
POS.	COMPONENT	POS.	COMPONENT	POS.	COMPONENT
1	BODY	13	BUSH BEARING	25	SUPPORT COVER
2	CLAPPER	14	PIN	26	LIMIT SWITCH SUPPORT
3	SEAL	15	DISTANCER BUSHING	27	LIMIT SWITCH
4	FLANGE SEAL	16	CIR-CLIP	28	POSITION INDICATOR
5	DRIVE SHAFT	17	BUSH BEARING	29	O-RING SEAL
6	SHAFT	18	COTTER	30	PIN
7	ACTUATOR SUPPORT	19	PIN	31	THREADED ROD
8	COUNTERWEIGHT ARM	20	FRICTION WASHER	32	PIN
9	COUNTERWEIGHT SUPPORT	21	RUBBER RING	33	WASHER
10	COUNTERWEIGHT	22	SOLID COVER	34	SCREW
11	ACTUATOR	23	RUBBER RING	35	NUT
12	SUPPORT COVER	24	GUIDE COVER	36	COUNTER NUT

table 3

C.M.O.

Amategui Aldea 142, 20400 Txarama-Tolosa (SPAIN)

Tel: 902 40 80 50 / Fax 902 40 80 51 / cmo@cmo.es <http://www.cmo.es>

TEC-ME.ES00

page 14



BUTTERFLY VALVE

ME SERIES

INFORMATION AND DIMENSIONS OF FLANGES & WIDTHS OVER FLATS

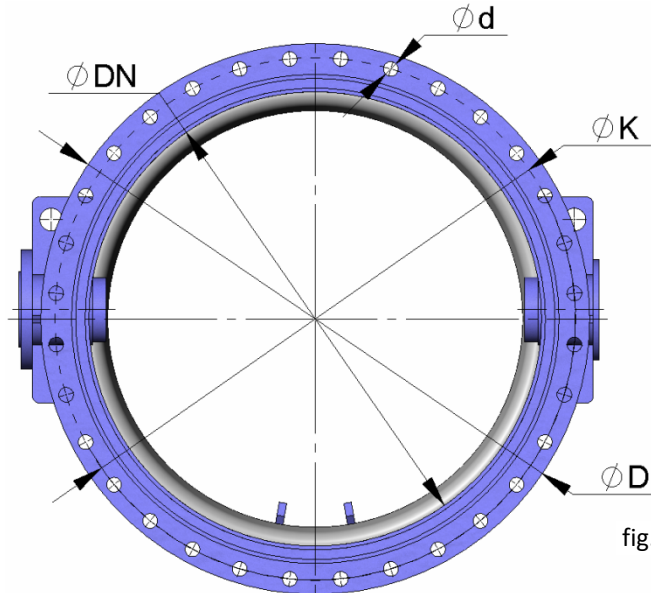
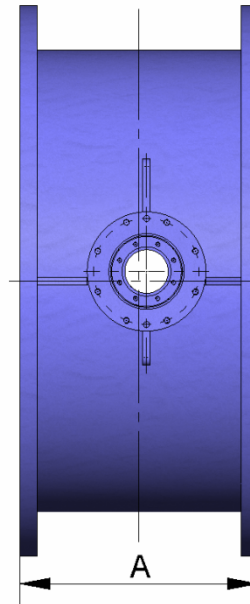

fig.28



DN	FLANGE DRILLING in accordance with EN 1092-2 PN10						TIGHTENING TORQUE (Nm)
	A1*	A2*	Qty.	Ød	ØD	ØK	
200	152	230	8	22	340	295	126
250	165	250	12	22	395	350	126
300	178	270	12	22	445	400	126
350	190	290	16	22	505	460	126
400	216	310	16	26	565	515	309
500	229	350	20	26	670	620	309
600	267	390	20	30	780	725	455
700	292	430	24	30	895	840	455
800	318	470	24	33	1015	950	615
900	330	510	28	33	1115	1050	615
1000	410	550	28	36	1230	1160	821
1200	470	630	32	39	1455	1380	1089
1400	530	710	36	42	1675	1590	1320
1600	600	790	40	48	1915	1820	1978
1800	670	870	44	48	2115	2020	1978
2000	760	950	48	48	2325	2230	1978
2200	---	1030	52	56	2550	2440	2976
2400	---	1110	56	56	2760	2650	2976
2600	---	1190	60	56	2960	2850	2976
2800	---	1270	64	56	3180	3070	2976
3000	---	1350	68	62	3405	3290	3776

\* → A1: Short series in accordance with EN 558 SERIES 13  
 A2: Long series in accordance with EN 558 SERIES 14

REMARKS: Other sizes and standards can be supplied to order.

table 4

CMO's ME butterfly valves have two width over flats options (level "A" fig. 28): short series and long series.

Flange drilling varies depending on customer needs, but is commonly carried out in accordance with Standard EN 1092-2 PN10.

Table 4 details the most typical levels for drilling flanges and width over flats. The required torque for installation between flanges is also detailed.