



ROUND LOUVRE DAMPER

LR SERIES

05/04/2016

BIDIRECTIONAL round multilouvre damper butterfly valve

- Round multilouvre damper butterfly valve, shutter type, with bidirectional design.
- Designed for pneumatic transport of air or gases at different temperatures.
- Option of manufacturing "WAFER" type or with bored flanges.
- Watertight integrity between 97% and 99%.
- Option of using an air sealing system to increase watertight integrity up to 100%.
- Various packing materials available.
- Face-to-face distance in accordance with **C.M.O.** standard. Other distances upon request.

General applications:

- These multilouvre damper butterfly valves are suitable to work with a wide range of air and gases. They are particularly suitable for controlling the flow of gas in pipelines. Used mainly in:
 - Cogeneration plants. - Thermal power stations.
 - Electrical power stations. - Chemical plants.
 - Energy sector. - ...

Sizes:

- From DN 400 up to DN 3000 (larger sizes on request). Check with **C.M.O.** for the general dimensions of a specific round multilouvre damper butterfly.

Working (ΔP):

- Maximum standard work pressure is 0.5 kg/cm²; greater pressures upon request.

Joint flanges:

- There are two options to secure these valves to the conduit:
 - Flange connection: The valve is manufactured with "WAFER" type design.
 - Bolting the flanges: The valve is manufactured with bored flanges.
- In both variants, the flange connections and openings are in line with **C.M.O.** standard, although these can be tailored to customer requirements upon request.

Watertight integrity:

- The standard watertight percentage for these C.M.O. valves varies between 97% and 99%. 100% watertight integrity can also be obtained using systems sealed by air injection (to order).

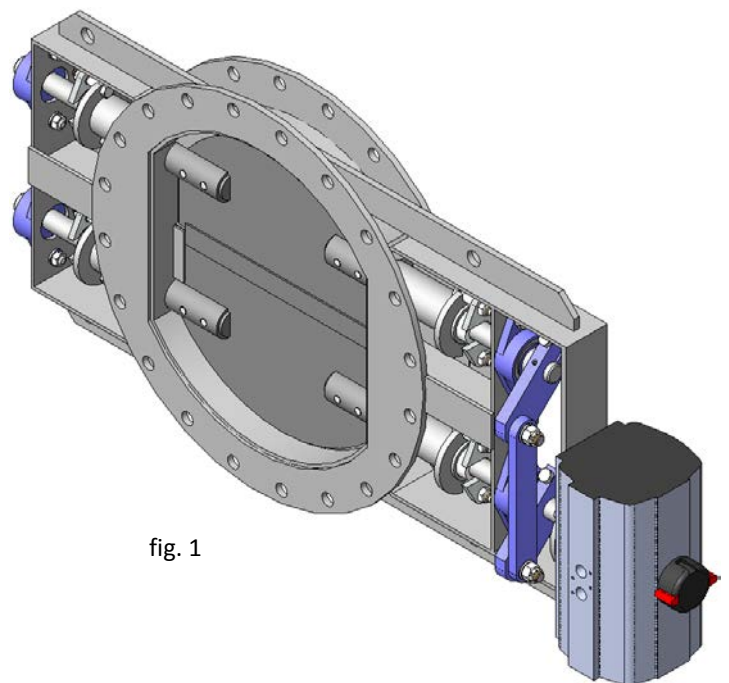

fig. 1



ROUND LOUVRE DAMPER

LR SERIES

Directives:

- Machinery Directive: **DIR 2006/42/EC (MACHINERY)**.
- Pressure Equipment Directive: **DIR 97/23/EC (PED) ART.3, P.3.**
- Explosive Atmospheres Directive: **DIR 94/9/EC (ATEX) CAT.3 ZONE 2 and 22 GD.** For further information on categories and zones please contact **C.M.O.**'s Technical-Commercial Department.

Quality dossier:

- All valves are tested at **CMO** and material and testing certificates can be supplied on request.
- The watertight integrity of the seat area is measured with gauges.

Advantages of C.M.O.'s "LR Model".

These **LR** valves are mechanically welded.

The main elements which make up these multilouvre damper butterflies are the body, fitted with several louvres (shutter type) inside, which turn on several duly aligned parallel shafts. Each rotation shaft is aligned relative to its louvre, and these are aligned relative to the central plane of the body (fig. 2), meaning the direction of flow is indifferent as the valve is bidirectional.

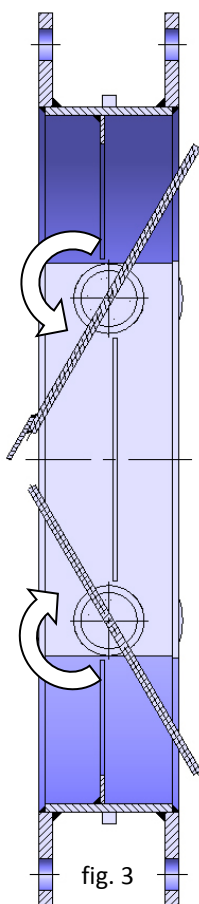

The movement of the louvres when opening or closing the valve can be convergent or parallel. When it is convergent (fig. 3), the shafts of each louvre rotate in opposite direction, meaning they will be on the same side when closing the louvres. On the other hand, if the valve is designed with parallel movement (fig. 2), all the shafts of the louvres turn in the same direction, meaning they will be on opposite sides when the louvres close.

These valves have a single actuator shaft which the actuator is mounted on. This shaft will be connected to the other shafts by rods and levers in order to transmit the rotational movement generated by the actuator. The movement of the valve will be divergent (fig. 4) or parallel (fig. 5) depending on the design of these connections.

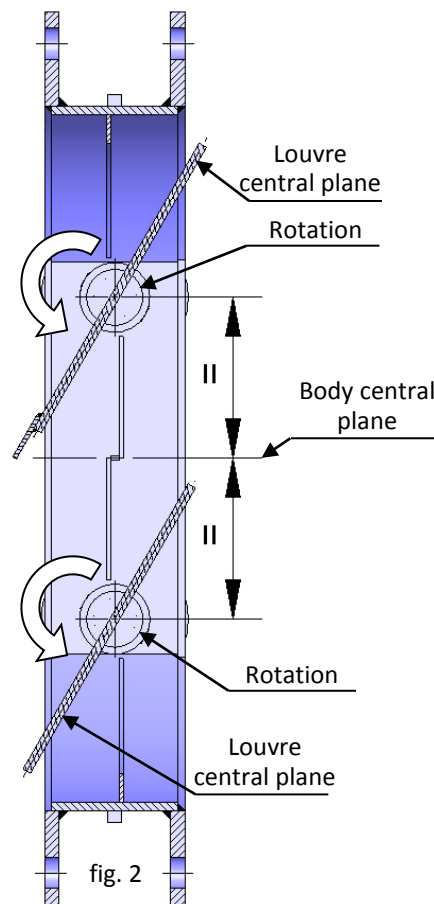



ROUND LOUVRE DAMPER

LR SERIES

The watertight integrity of these valves ranges between 97% and 99%. If the body is designed without sealing rims, watertight integrity will be 97%. However, greater watertight integrity can be achieved if rims are fitted for the louvres to close on them.

Whenever 100% watertight integrity is required, the design of the valve can be duly adapted, resulting in a slight variation from the standard. The face-to-face distance of the valve increases in order to include two parallel rows of louvres, and a fan air injection system is attached to the body.

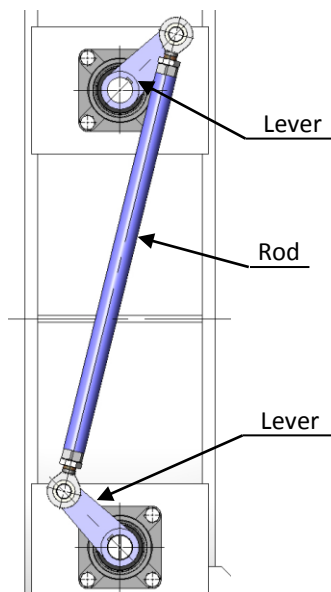

fig. 4

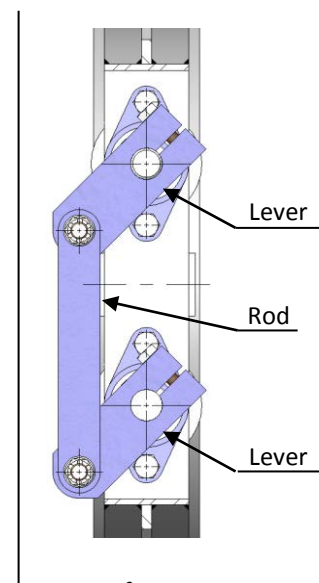

fig. 5

The **LR** valve body consists basically of a collar of the same interior diameter as the conduit where it is installed, with a flange on each side. If the valve is “WAFER” type, assembly in the conduit is by way of flanges (“sandwich” type) (fig. 6). In the case of bolted flanges, the valve is mounted in the conduit bolted to the flanges (fig. 7).

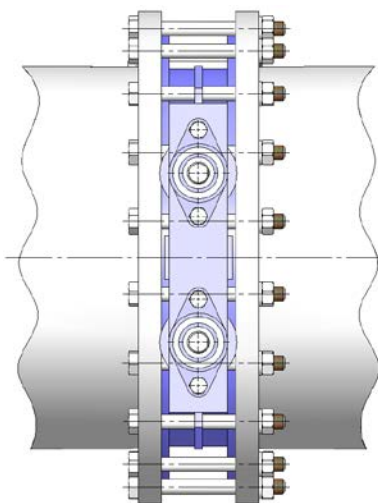

fig. 6

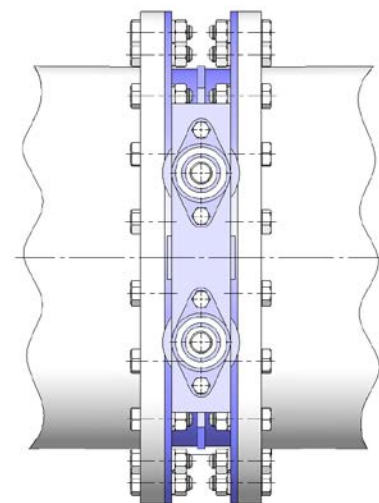

fig. 7

Both the face-to-face distance and the flange boring are defined in accordance with **C.M.O.** standards; however, they can also be manufactured in accordance with customer requirements.

These damper butterflies are designed for the rotation shafts to remain in horizontal position, although they can be designed for assembly in other positions upon request.

Since these valves are designed to control the passage of air or gases, these flows are occasionally at very high temperatures. Specific materials are used for high temperatures (e.g. AISI316, AISI 310, etc.) in order to ensure the valve responds correctly under these conditions.

ROUND LOUVRE DAMPER

LR SERIES

There are manual and automatic actuators to operate these valves. In either case, the drive system is positioned far away from the valve when the valve is to work at very high temperatures. Exterior

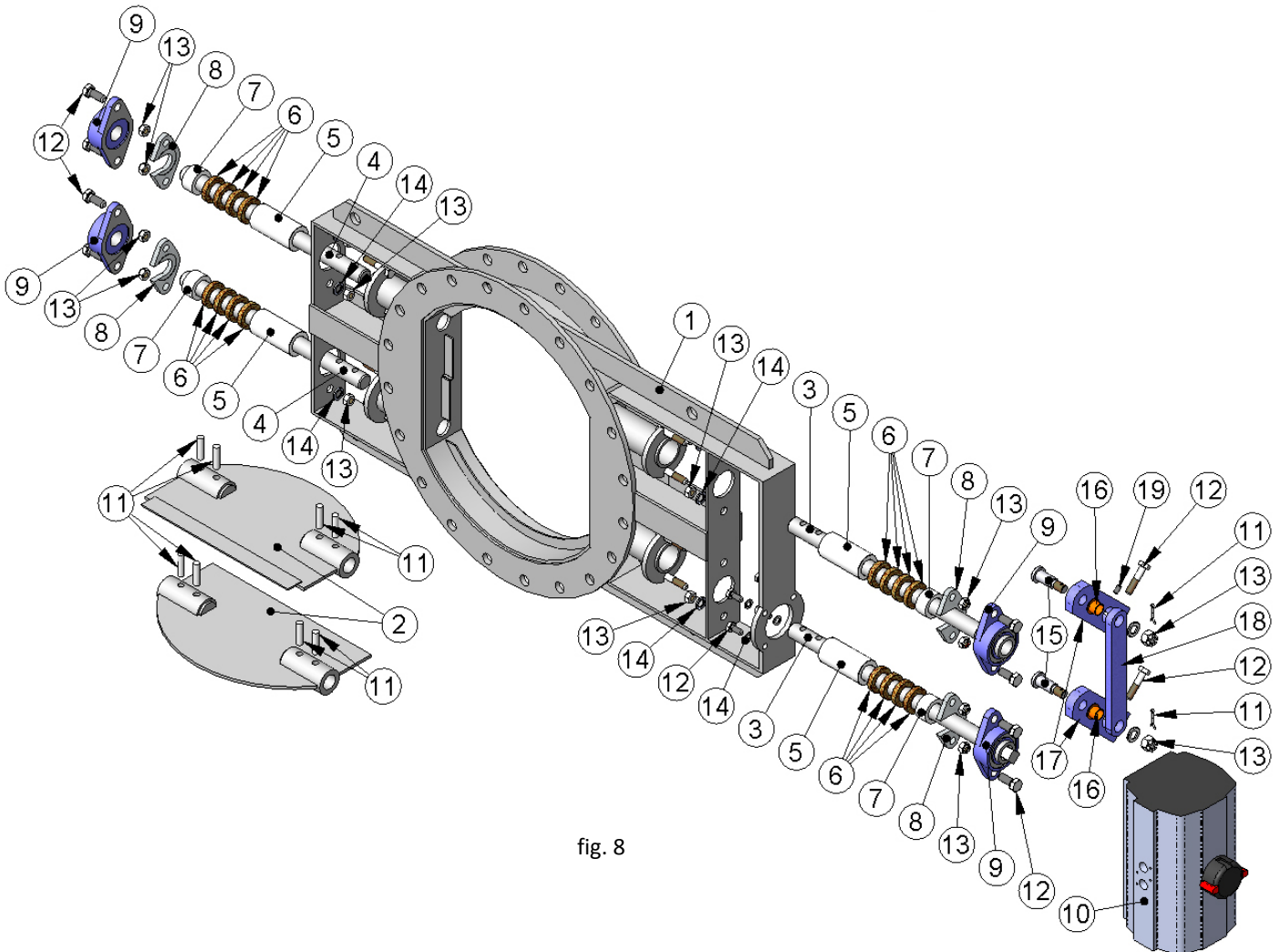

fig. 8

insulation, heatsinks or interior insulation based on refractory materials can also be used.

STANDARD COMPONENTS LIST					
POS.	COMPONENT	POS.	COMPONENT	POS.	COMPONENT
1	Body	7	Packing gland bushing	14	Washer
2	Louvres	8	Packing gland flange	15	Bolt
3	Drive shaft	9	Support with bearing	16	Self-lubricated bushing
4	Driven shaft	10	Actuator	17	Lever
5	Spacer	11	Pin	18	Rod
6	Packing	12	Bolt	19	Setscrew
		13	Nut		

table 1

C.M.O.

Amategui Aldea 142, 20400 Txarama-Tolosa (SPAIN)

TEC-LR.ES00

Tel. National: 902.40.80.50 Fax: 902.40.80.51 / Tel. International: 34.943.67.33.99 Fax: 34.943.67.24.40

cmo@cmo.es <http://www.cmo.es>

page 4



ROUND LOUVRE DAMPER

LR SERIES

DESIGN CHARACTERISTICS

1- BODY

The body of this type of damper butterflies is usually mechanically welded. Its geometry consists basically of a collar of the same interior diameter as the conduit in which it is installed, with a flange on each side. In the case of "WAFER" type valves, these flanges will not include boreholes (fig. 9). When a valve with bored flanges is required (fig. 10), the flanges will be bored in accordance with **C.M.O.** standard, as will the face-to-face distance dimension of the body. However, both the opening and the flange standard can be tailored in accordance with customer requirements upon request.

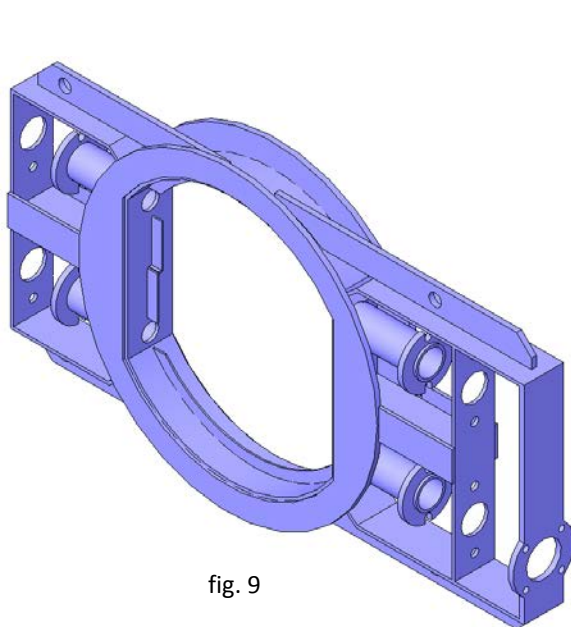

fig. 9

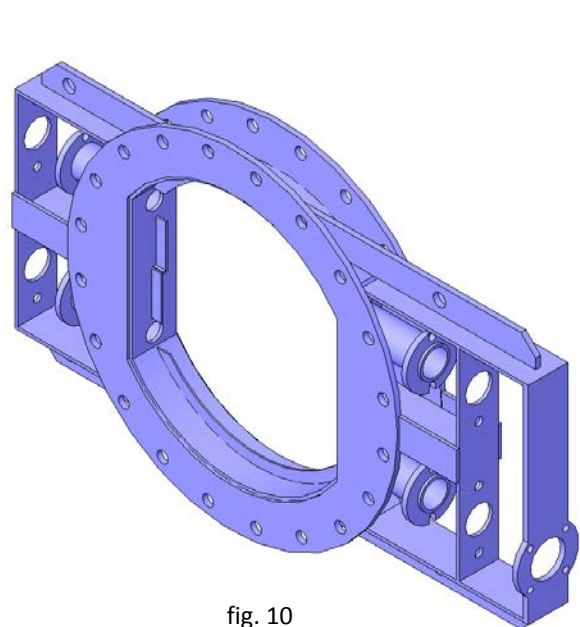
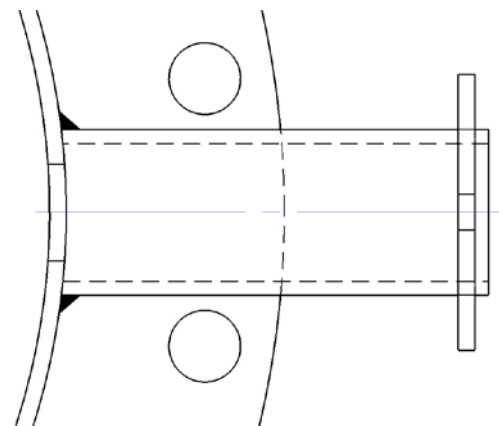

fig. 10

There are two orifices in each of the louvres, on both sides of the collar, with pieces of pipe welded on the outside (fig. 11). These are perfectly aligned and coincide with the rotation shaft of each louvre. The shafts are introduced in these pipes to support and operate the louvres. A packing gland system is used in all pipes in order to ensure the watertight integrity of these areas and prevent leakages of gas from inside the body. This system comprises multiple packing lines which, when oppressed by way of a gland flange and bushing, achieves the watertight integrity between the body and the shafts. The choice of packing material depends mainly on the working temperature.





ROUND LOUVRE DAMPER

LR SERIES

The watertight integrity offered by this type of valves is 97%. Whenever greater watertight integrity is required, special rims fitted inside the body and on the louvres can be used to improve watertight integrity when closing.

100% watertight integrity can be achieved by manufacturing a special valve. The face-to-face distance of the body is increased in order to fit two parallel rows of louvres. An air connection is made in the body between these two rows, through which air will be injected with the help of a fan, thus achieving 100% watertight integrity through air sealing.

The construction materials used are highly varied, and are chosen in accordance with the valve requirements, the work temperature, pressure, dimensions, etc: Some of the most commonly used materials are: S275JR carbon steel, stainless steel AISI 304, AISI 316, etc. However, other special materials such as steel H11, 16Mo3, AISI 310, etc., can also be used.

As standard, carbon steel damper butterflies are coated with an anti-corrosive protection of 80 microns of EPOXY, colour RAL 5015. However, other types of anti-corrosion protections are available.

2- LOUVRES

The louvres of these damper butterflies are fitted with "rectangular" sheets with bushing on both ends (fig. 12), through which the shafts are introduced. The louvres turn on these shafts and are driven by the actuator shaft. The joints between louvres and shafts use pins.

The louvres of the ends will have a circular side in order to adapt to the shape of the body.

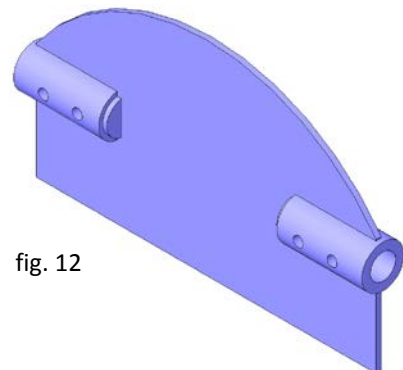

fig. 12

The louvres are designed based on the dimensions of the conduit, the working pressure and the number of louvres

requested by the customer. When the situation so requires, the louvres can be fitted with ribs and reinforcements to guarantee the necessary robustness (fig 13).

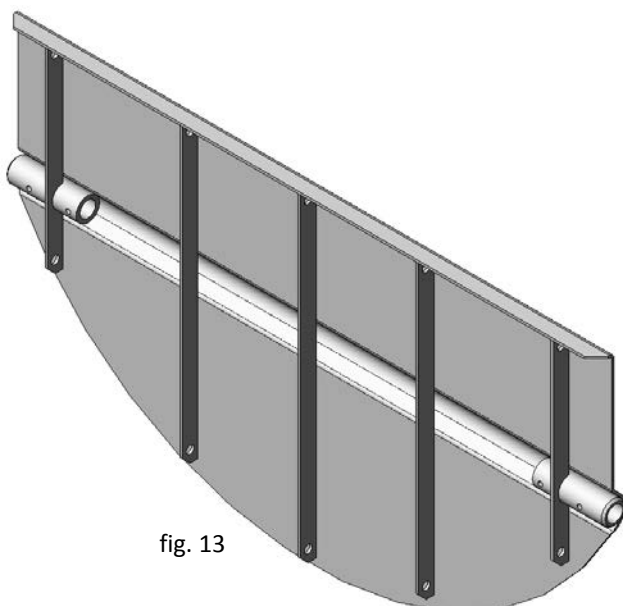

fig. 13

As mentioned above, whenever a valve with 100% watertight integrity is required, the design varies from the standard and, amongst other peculiarities, the valve will be fitted with two parallel rows of louvres, meaning there will be twice as many louvres as usual, as shown in fig. 14.



ROUND LOUVRE DAMPER

LR SERIES

The louvres are generally made of the same material as the body, although other materials or combinations can be produced upon request. The materials are chosen in accordance with the requirements of each valve, the working temperature, pressure, dimension, etc. Some of the most commonly used materials are: S275JR carbon steel, stainless steel AISI 304, AISI 316, etc. However, other special materials such as steel H11, 16Mo3, AISI 310, etc., can also be used.

As standard, carbon steel or iron valves are painted with an anti-corrosive protection of 80 microns of EPOXY colour RAL 5015. However, other types of anti-corrosion protections are available.

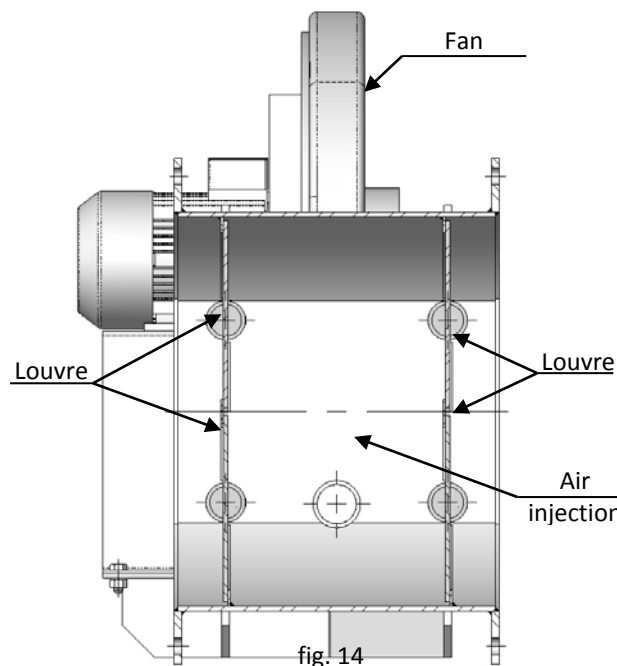

3- SEAT

Different types of seats are available according to the working application:

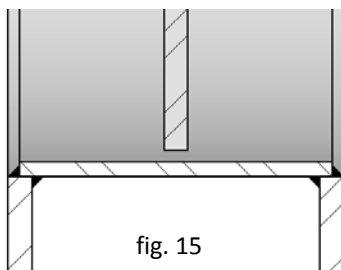

- **Seat 1:** In this type of seal there is no contact between the body and the louvres (fig. 15). The estimated leak is 3% of the pipe flow. There is a series of margins which are determined, firstly, between the interior diameter of the body and the exterior dimensions of the louvres, and, secondly, between these louvres, in order for the valve to open and close without any problems. We therefore calculate that this type of seal achieves watertight integrity of 97%.

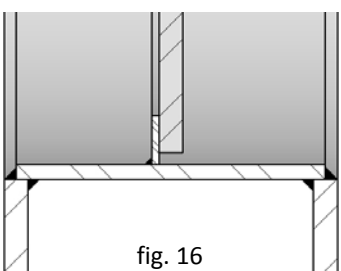

- **Seat 2:** Metal/metal seal. This type of seal includes special rims which adapt to both the body and the rims. The purpose of these rims is to close on them achieving a metal/metal seal (fig. 16). The estimated leak is 1% of the pipe flow. The thickness of these rims means they can be handled easily to adjust the louvres. We therefore calculate that this type of seal achieves watertight integrity of 99%.



ROUND LOUVRE DAMPER

LR SERIES

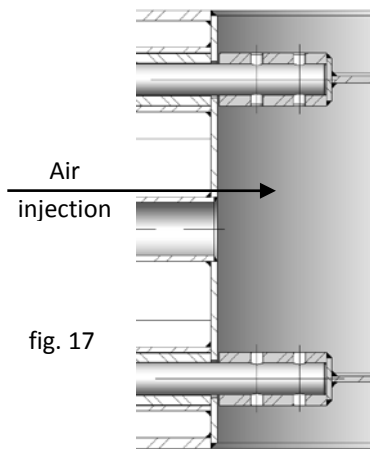

- **Seat 3:** Air-sealed. This type of seal is particularly special. The valve is designed with two parallel rows of louvres, between which air is injected in order to completely separate the gases on both sides of the valve (fig. 17).

This type of valve requires double the number of louvres of a conventional valve. These rims close against the rim system in the body and the louvres. In order to inject air in the seal, a fan system with a check valve is attached (fig. 18), meaning the conduit gases cannot leave through the fan pipe when the multilouvre damper butterfly is open.

We therefore calculate that this type of seal achieves watertight integrity of 100%.

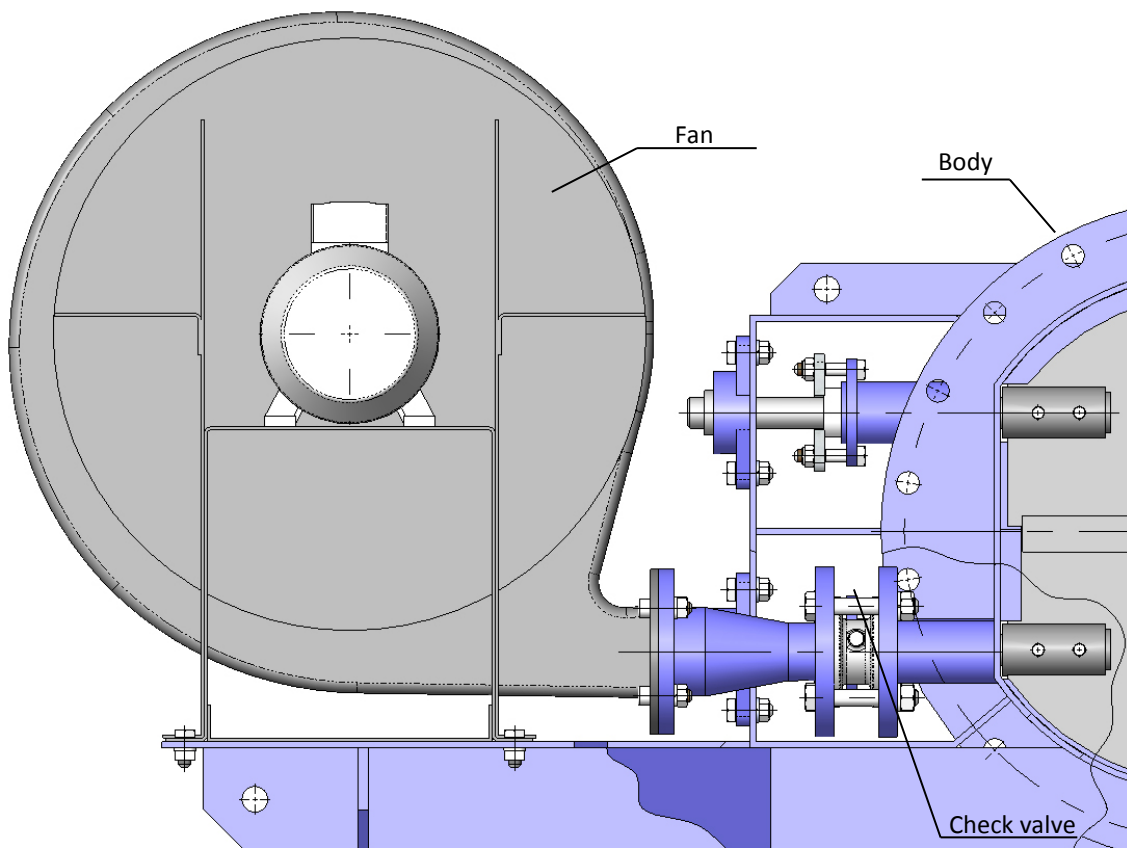

fig. 18



ROUND LOUVRE DAMPER

LR SERIES

4- PACKING

C.M.O.'s standard packing comprises several lines of SYNTHETIC+PTFE packing which provide watertight integrity between the shafts and the body, preventing any type of leakage into the atmosphere (fig 19). It is located in an easily accessible place and can be replaced without dismantling the pipeline valve. Below we indicate various types of packing available according to the application where the damper is found:

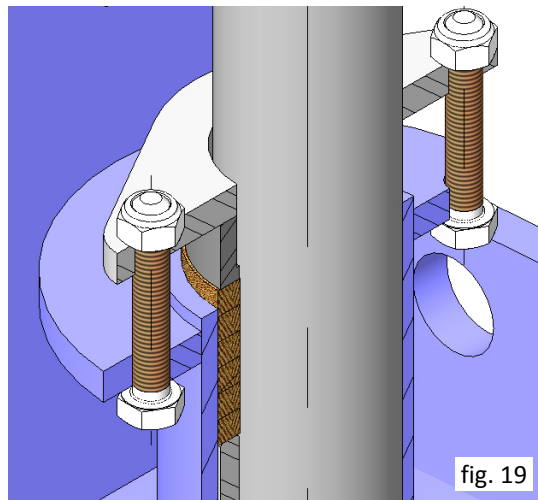

GREASED COTTON (Recommended for hydraulic services)

This packing is composed of braided cotton fibres soaked in grease both inside and out. It is for general use in hydraulic applications in both pumps and valves.

DRY COTTON

This packing is composed of cotton fibres. It is for general use in applications with solids.

COTTON + PTFE

This packing is composed of braided cotton fibres soaked in PTFE both inside and out. It is for general use in hydraulic applications in both pumps and valves.

SYNTHETIC + PTFE

This packing is composed of braided synthetic fibres soaked in PTFE both inside and out. It is for general use in hydraulic applications in both pumps and valves and in all types of fluids, especially corrosive ones, including concentrated and oxidising oils. It is also used in gas with solid particles in suspension.

GRAPHITE

This packing is composed of high-purity graphite fibres. A diagonal braiding system is used and it is impregnated with graphite and lubricant which helps to reduce porosity and improve operation.

It has a wide range of applications as graphite is resistant to steam, water, oils, solvents, alkali and most acids.

CERAMIC FIBRE

This packing is composed of ceramic material fibres. It is used mainly with air or gases at high temperatures and low pressures.



ROUND LOUVRE DAMPER

LR SERIES

PACKING			
Material	P(bar)	Max. Temp. (°C)	pH
Greased cotton	10	100	6-8
Dry cotton (AS)	0.5	100	6-8
Cotton + PTFE	30	120	6-8
Synthetic + PTFE	100	-200+270	0-14
Graphite	40	650	0-14
Ceramic Fibre	0.3	1400	0-14

table 2

NOTE: More details and other materials available to order.

5- SHAFTS

The shafts of **C.M.O.**'s **ML** and **MF** multilouvre damper butterflies are solid and manufactured in stainless steel (AISI 304, AISI 316, AISI 310, etc.). These characteristics make it highly resistant and provide excellent properties against corrosion.

Pins (fig. 20) are used to join the louvres and the shafts, which cross the louvre bushing from side to side, including the part of the shafts located inside.

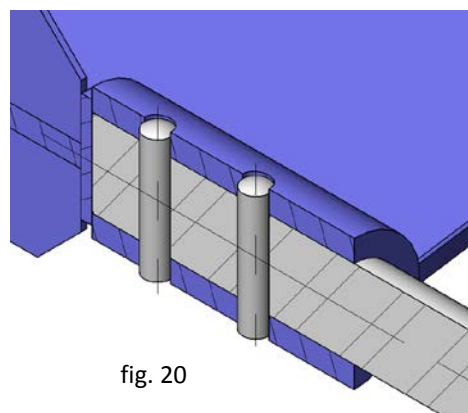

fig. 20

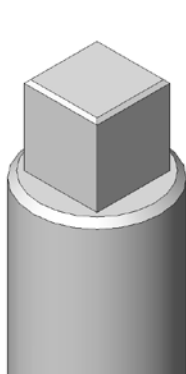

fig. 21

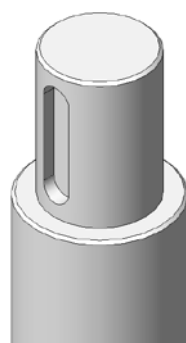

fig. 22

These damper valves have several louvres, each of which is supported by two semi-shafts. However, each valve has a single actuator shaft, one end of which is joined to a louvre, whilst the opposite end can have a square head system (fig. 21) or a slot (fig. 22) in order to transmit the torque generated by the actuator.

The other shafts are joined to the actuator shaft using rods and levers so all louvres close and open in a synchronised manner. These shaft joint systems can be used to adjust the louvre seal.

Commercial support pieces fitted with self-lubricating bearings are used to ensure the shafts can turn without any problems. These support pieces are bolted in the body and each semi-shaft has its own support (fig. 23).

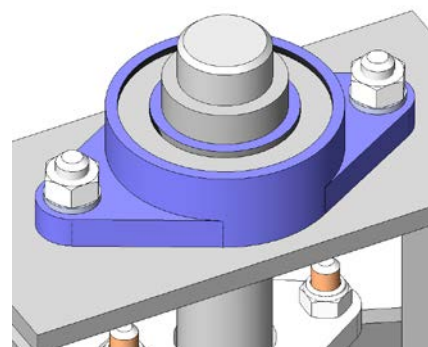

fig. 23

ROUND LOUVRE DAMPER

LR SERIES

6- PACKING GLAND

As explained above, a packing gland system is used to achieve the watertight integrity of the shaft. This comprises multiple packing lines which are oppressed by way of a gland flange and bushing. The combination of packing gland flange plus packing gland bushing (fig. 24) allows a uniform pressure and force to be applied throughout the packing, thus guaranteeing there are no leakages between the body and the shafts.

As a general rule, both the gland flange and the gland bushing are made of stainless steel AISI 316. However, other materials can be used to order.

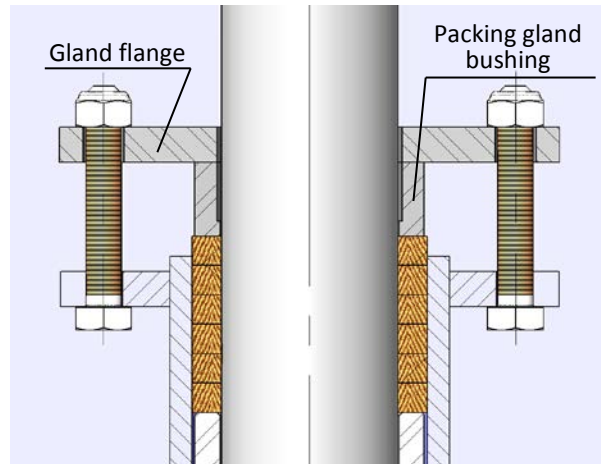

fig. 24

7- ACTUATORS

The damper butterfly actuator system is located in one of the body support pieces. The actuator is bolted to the body and transmits the torque generated to the actuator shaft, which in turn transmits it to the rest of the shafts through rods and levers. This means all the louvres move in a synchronised manner.

Our damper butterflies are supplied with several types of actuator, bringing the advantage that, thanks to the **C.M.O.** design, they can be interchanged.

This design allows customers to change the actuators themselves and no extra assembly accessories are required.

The total dimensions of the damper butterfly may vary in accordance with the type of actuator chosen.

Manual:

- Gearbox (fig. 28)
- Lever (fig. 25)
- Square-head (fig. 30)
- ...

Automatic:

- Electric actuator (fig. 31)
- Linear pneumatic cylinder (fig. 29) *
- Pneumatic cylinder ¼ turn (fig. 26) *
- Single acting pneumatic cylinder (fig 27) *

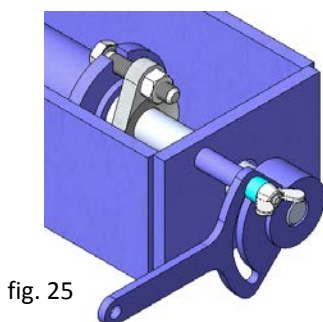

fig. 25

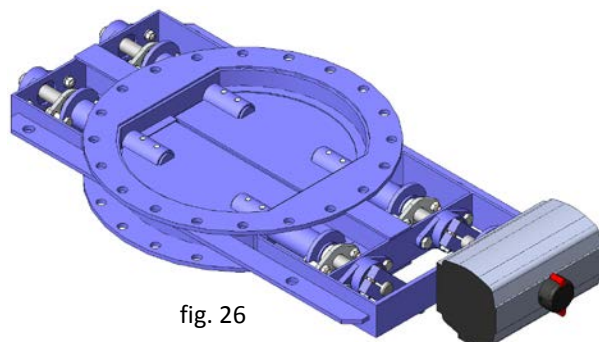

fig. 26

C.M.O.

Amategui Aldea 142, 20400 Txarama-Tolosa (SPAIN)

TEC-LR.ES00

Tel. National: 902.40.80.50 Fax: 902.40.80.51 / Tel. International: 34.943.67.33.99 Fax: 34.943.67.24.40

cmo@cmo.es <http://www.cmo.es>

page 11



ROUND LOUVRE DAMPER

LR SERIES

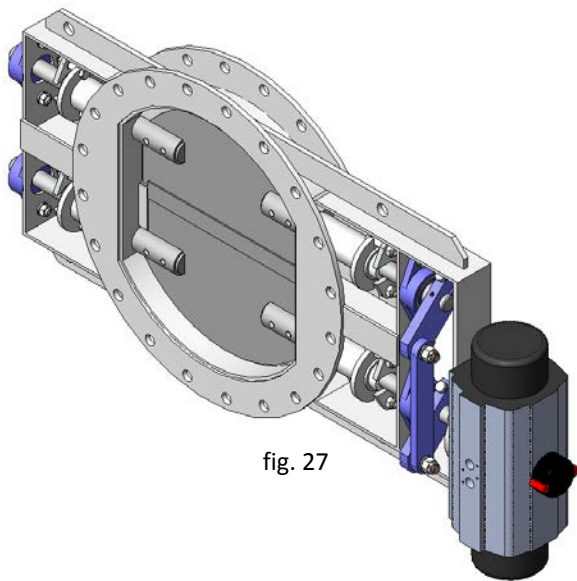

fig. 27

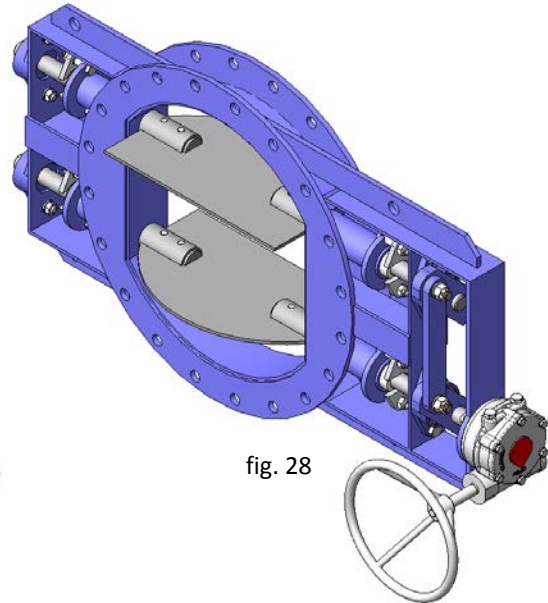

fig. 28

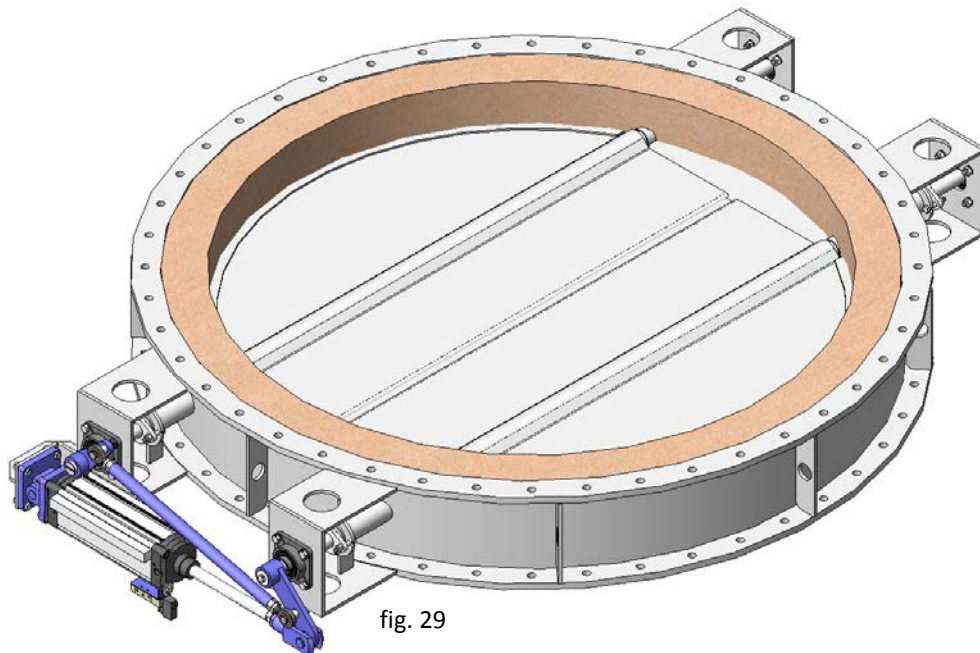

fig. 29

* → Speed regulators must be fitted when the multilouvre damper butterflies are fitted with pneumatic drive. In these cases the minimum time of each operation (opening or closing) is 6 seconds.

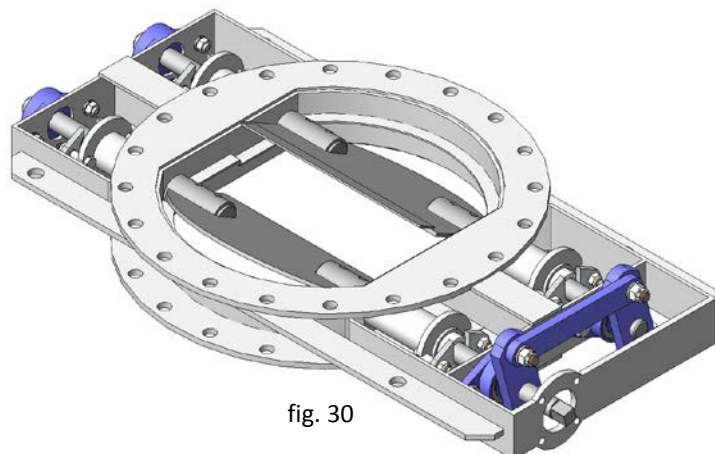
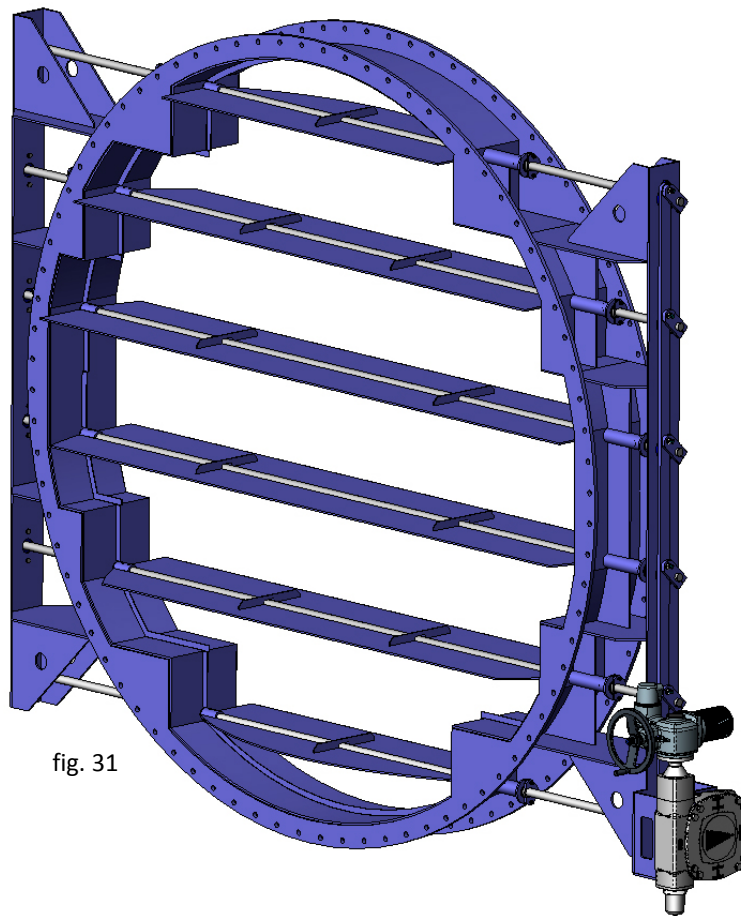

fig. 30



ROUND LOUVRE DAMPER

LR SERIES



A range of accessories has also been developed to adapt the damper butterflies to customer requirements. Some of these are indicated below. Please check with our engineers for any accessories you require which are not in the list.

Wide range of accessories available:

- Mechanical stoppers
- Locking devices
- Emergency manual actuators (fig.32)
- Electrovalves
- Positioners
- Limit switches (fig. 33)
- Proximity detectors
- ...

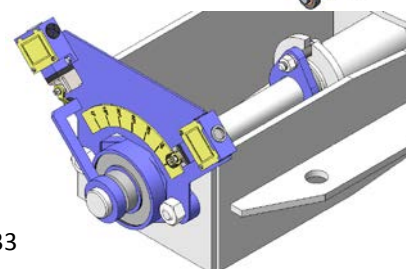
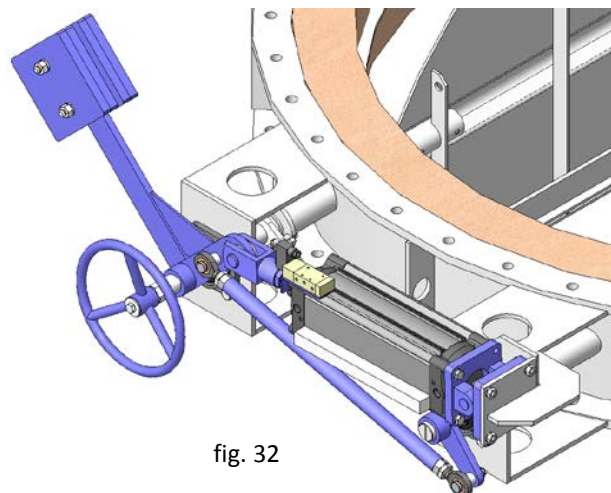

ACCESSORIES AND OPTIONS

Different accessories are available to adapt the multilouvre damper butterflies to specific working conditions such as:

- **Mirror-polished louvres:** Mirror-polished louvres are especially recommended in the food industry and, in general, in applications in which solids can stick to the louvres. It is a solution to ensure the solids slide off and do not stick to the louvres.
- **PTFE coated louvres:** As with the mirror-polished louvres, it improves the louvre damper butterfly's resistance to products that can stick to the louvres.
- **Stellite louvres:** This consists of providing stellite in the louvre sealing area to protect them from abrasion.
- **Scraper in the packing:** Its function is to stop the passage of harmful particles and prevent damage to the packing.
- **Air injection in the packing:** By injecting air in the packing, an air chamber is created which improves watertight integrity.
- **Cased body:** Recommended in applications in which the fluid can harden and solidify inside the valve's body. An external casing keeps the body temperature constant, preventing the fluid from solidifying.
- **Flushing holes in body:** Several holes are drilled in the body to flush air, steam or other fluids out with the aim of cleaning the valve seat before sealing.
- **Mechanical limit switches, inductive switches and positioners:** Installation of limit switches (fig. 33) or inductive detectors to indicate specific valve position, and positioners to indicate continuous position.
- **Electrovalves:** For the distribution of air to the pneumatic actuator.
- **Connection boxes, cabling and pneumatic piping:** Units supplied fully assembled with all the necessary accessories.
- **Mechanical stroke limiters (mechanical stops):** These are used to mechanically adjust the movement, limiting the turning required of the damper butterfly louvres.
- **Mechanical locking system:** Allows the valve to be mechanically locked in a set position for long periods.
- **Emergency manual drive:** Allows manual operation of the damper butterfly in the event of power or air failure (fig 32).
- **Interchangeable actuators:** All actuators are easily interchangeable.
- **Epoxy coating:** All stainless steel bodies and components of **C.M.O.**'s multilouvre damper butterflies are coated with a layer of EPOXY, which makes them resistant to corrosion and gives an excellent surface finish. **C.M.O.**'s standard colour is blue RAL-5015.



ROUND LOUVRE DAMPER

LR SERIES

OPTIONS FOR HIGH TEMPERATURES

If a damper butterfly is required to work at high working temperatures, there are different options available in line with the temperature and the space for the valve.

1- Elongated supports (fig. 34):

When the multilouvre damper butterfly has to work at high temperatures, there is the option to elongate the body supports. This moves the bearings and the actuator away from the source of heat, protecting them from possible damage due to the high temperatures of the conduit.

Whenever the valve is fitted with a manual actuator, this allows the operator to use it without any risk of burns.

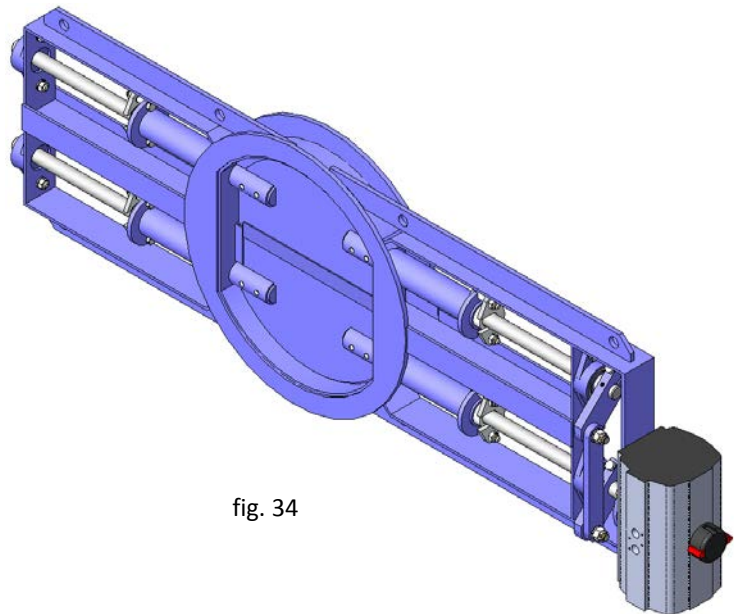

fig. 34

2- Insulation (fig. 35):

Whenever the damper butterfly has to work at high temperatures and it is necessary to avoid unnecessary loss of heat through the valve, e.g. to maintain optimum performance of the facility, there is the option of protecting the valve body with exterior insulation.

Sufficient free space is left around the body in order to fit the insulation whenever the customer deems appropriate. The packing gland, bearings and drive systems therefore remain easily accessible and maintenance work can be carried out without having to remove the insulation.

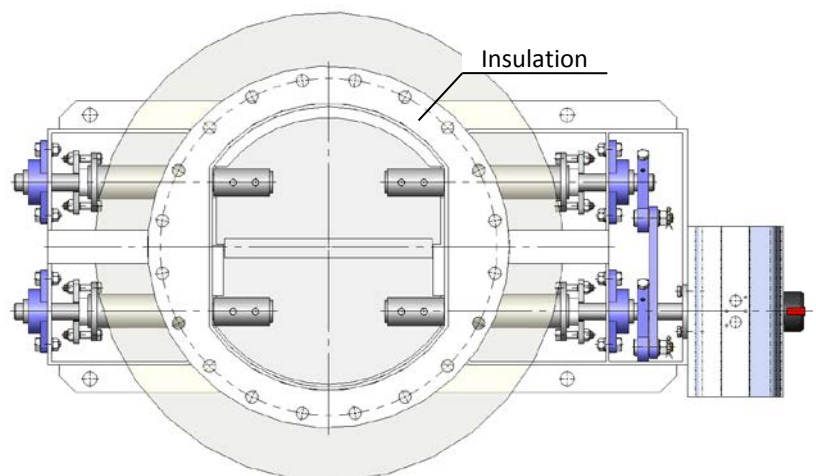

fig. 35



ROUND LOUVRE DAMPER

LR SERIES

3- Heatsinks (fig. 36):

Heatsinks can be installed in facilities in which the valve works at high temperatures and there is not enough space to extend the body support pieces (or the length required is greater than normal). They are installed mainly in the shafts, since they are solid and have great thermal conductivity. The aim is to dissipate the heat and bring the temperature of the shafts down in the areas where the bearings and the actuator are assembled. This allows them to work at a lower temperature, causing less wear and tear and extending their working life.

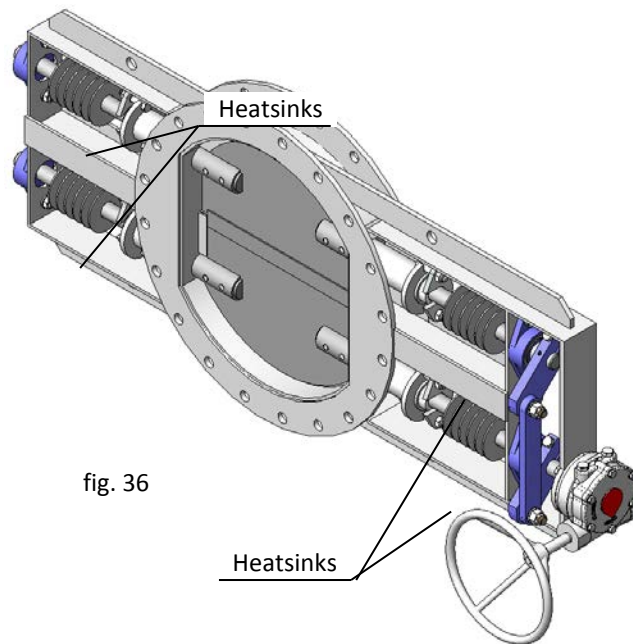

4- Interior insulation (fig 37):

This type of damper butterfly is occasionally installed in conduits where the working temperature is very high. It may be the case that the temperature is too hot for the option of fitting insulation or that the valve is to be installed as close as possible to the source of heat. In these cases the inside of the body can be insulated with refractory material.

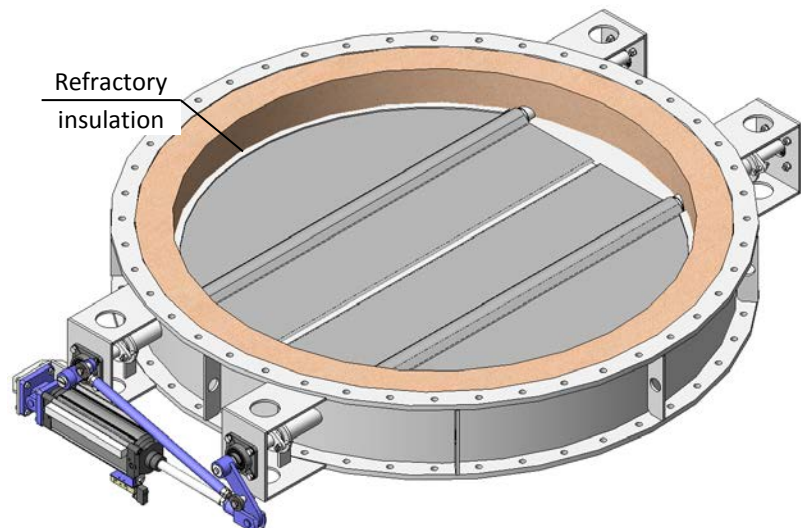

In valves which use this system, the diameter of the collar in the body fig. 37 illy significantly larger than the nominal diameter of the conduit. The reason for this characteristic is that the refractory insulator is attached to the interior surface of the collar in the body. In consequence, higher temperatures will require higher quantities of refractory material. For this reason, the difference between the nominal diameter of the conduit and the diameter of the body must be larger.



ROUND LOUVRE DAMPER

LR SERIES

GENERAL DIMENSIONS OF MULTILOUVRE DAMPER

As indicated previously, the face-to-face distance and general dimensions of LR multilouvre damper butterflies are defined in accordance with **C.M.O.** standard. However, since these valves depend on multiple variables, such as work pressure, temperature, dimensions of the conduit, etc., please contact **C.M.O.** if you wish to know the general dimensions of a round multilouvre damper in particular.

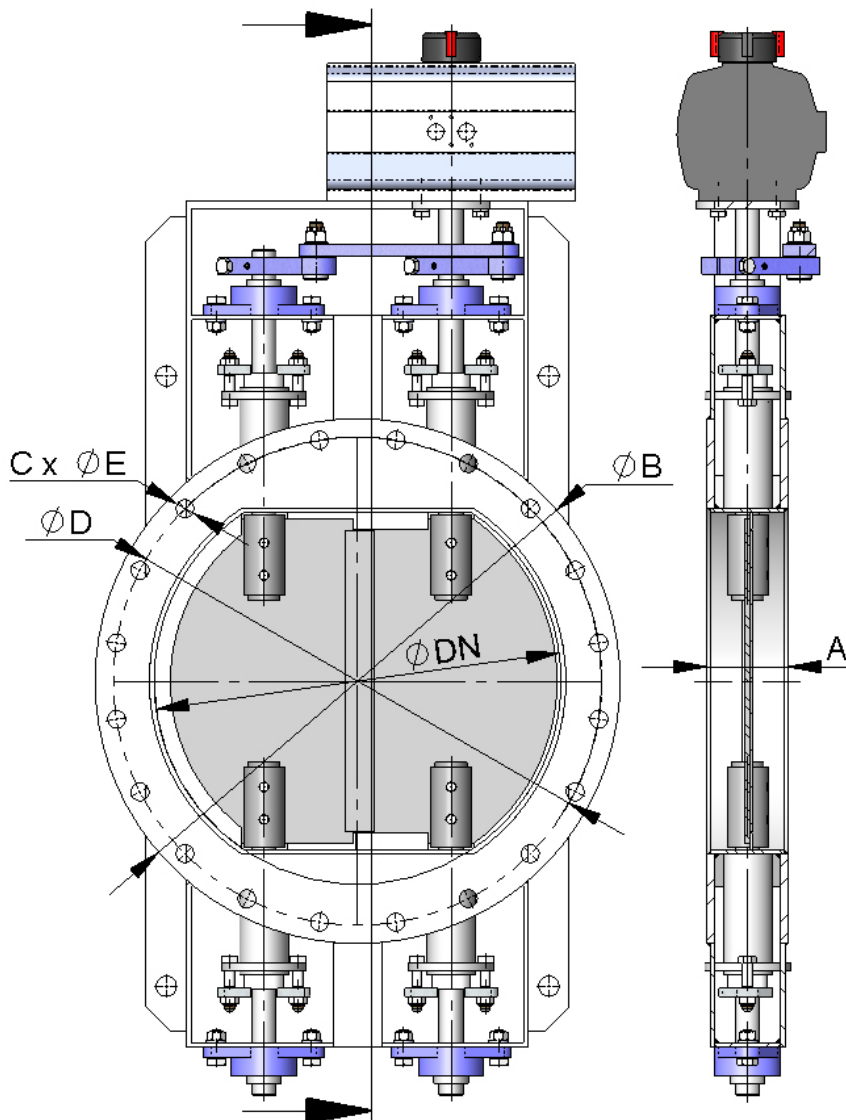

dimensions of a round multilouvre damper in particular.