

## BIDIRECTIONAL "WAFER" Type Knife Gate Valve

Rev. 07/04/2017

Bidirectional knife gate valve with "wafer" design.

Two-piece cast body, joined by screws, with internal guides for smooth movement of through conduit during operation.

Provides high flow rates with low pressure drop.

Various seal and gasket materials available.

Distance between faces up to DN600 in accordance with Standard UNE-EN 558 Basic Series 20. The rest in accordance with **C.M.O.** standard.

### General applications:

This knife gate valve is suitable for working with clean liquids or liquids with a concentration of bland solids:

- Drying plants.
- Sewage treatment.
- Food industry.
- Oil extraction.
- Paper Industry.
- Chemical plants
- Mining.
- Sludge.

**Sizes:** DN50 to DN2000 (other dimensions to order).

<b>Working (<math>\Delta P</math>):</b>	- DN50 a DN200: 10 Kg/cm <sup>2</sup>
	- DN250 y DN300: 7 / 10 Kg/cm <sup>2</sup>
	- DN350 y DN400: 6 / 10 Kg/cm <sup>2</sup>
	- DN450 y DN600: 4 / 10 Kg/cm <sup>2</sup>
	- DN700 a DN1400: 2 / 4 / 6 / 10 Kg/cm <sup>2</sup>
	- DN1600 a DN2000: 2 / 4 / 6 Kg/cm <sup>2</sup>

**Boring:** DIN PN10 and ANSI B16.5 (class 150).

### Other common flanges:

DIN PN 16.	JIS Standard.
DIN PN6.	Australian Standard
DIN PN25.	British Standard.

### Directives:

Machinery Directive: **DIR 2006/42/EC (MACHINERY)**.

Pressure Equipment Directive: **DIR 97/23/EC (PED) ART.3, P.3.**

Potentially Explosive Atmospheres Directive (optional): **DIR 94/9/EC (ATEX) CAT.3**

**ZONE 2 and 22 GD**, for information on categories and zones please contact CMO Technical-Sales Department.

### Quality dossier:

All valves are tested hydrostatically at CMO and material and test certificates can be provided.

Body test = working pressure x 1.5.

Seal test = working pressure x 1.1.



fig. 1

## ADVANTAGES OF CMO "UB MODEL"

The main characteristic of this valve is the body design. This is a body formed by two screwed parts which have been machined on the inside, providing the valve with capacity to work with fluids in both directions and with the same pressure.

The seal is located between the two parts of the body, and this seal is secured with the screws used to attach the two parts of the body. In valves DN50 to DN600 the seal has a metal core inserted in order to withstand the fluid pressure and allow the valve to shut off correctly. In valves over DN600 the two parts of the body have an outer rim to ensure the seal remains in position.

This seal design provides a completely flat seat with no internal cavities and avoids any build-up of solids in the seat area.

The stem on the CMO valve is made of 18/8 stainless steel. This is another added advantage, as some manufacturers produce it with 13% chrome and it gets rusty very quickly.

The handwheel is made of GJS-500 nodular cast iron. Some manufacturers produce them in normal cast iron which can lead to breakages in the event of very high operating torque or knocks. The yoke has a compact design with the bronze actuator nut protected in a sealed and lubricated box. This makes it possible to move the valve with a key, even without the handwheel (in other manufacturers' products this is not possible).

The pneumatic actuator's upper and lower covers are made of GJS-400 nodular cast iron, making them highly shock resistant. This characteristic is essential in pneumatic actuators.

The pneumatic cylinder sealing joints are commercial products and can be purchased worldwide. This means it is not necessary to contact CMO every time a sealing joint is required.

LISTA DE COMPONENTES ESTANDAR		
COMPONENT	IRON VERSION	STAINLESS STEEL
1- Body	GJS-500	CF8M
2-Through conduit	AISI304 / DUPLEX	AISI316 / DUPLEX
3- Seal Rim	AISI304	AISI316
4-Stuffing box seal	EPDM	EPDM
5- Seal	EPDM + ACERO	EPDM + ACERO
6- Seat	---	RCH 1000
7 -Support	S275JR	S275JR
8- Stem	AISI303	AISI303
9- Yoke	GJS-500	GJS-500
10- Stem nut	BRONCE	BRONCE
11- Check nut	ACERO	ACERO
12- Handwheel	GJS-500	GJS-500
13- Nut	5.6 ZINC	5.6 ZINC
14- Hood	ACERO	ACERO
15- Top cap	PLASTICO	PLASTICO

Table 2

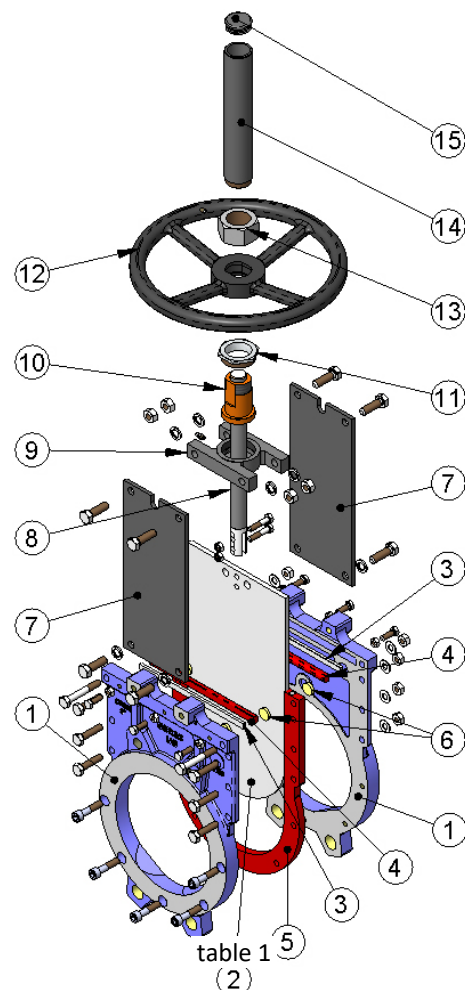

## DESIGN CHARACTERISTICS

### 1- BODY

Wafer design reinforced cast body, comprising two screwed parts. The stainless steel version has RCH1000 interior nylon slides which provide smooth movement of the through conduit; on the other hand, the GJS-500 versions do not require slides.

The internal surface of both parts is fully machined and assembled with screws to form a solid block. Designed with total passage, with the shape of the inside of the body preventing the build-up of solids in the seal area; this means that there is no cavitation in open position and, in consequence, there is no turbulence in the fluid and the loss of load is minimum, thus providing large flows.

The standard manufacturing materials are CF8M stainless steel and GJS-500 nodular cast iron. Other materials such as A216WCB carbon steel and stainless steel alloys (AISI316Ti, Duplex, 254SMO, Uranus B6, etc.) are available to order. As standard, the carbon steel or nodular cast iron valves are painted with EPOXY anti-corrosive protection (colour RAL 5015). Other types of anti-corrosive protections are available to order.

### 2- THROUGH CONDUIT

The standard manufacturing materials are AISI304 stainless steel in valves with iron body and AISI316 stainless steel in valves with CF8M body. In both cases, whenever the high pressures to withstand so require, we also make use of DUPLEX material.

Other materials or combinations can be supplied to order.

The through conduit is polished on both sides to provide a smooth contact surface with the resilient seal. At the same time, the through conduit is rounded to prevent the sealing joint from being cut. Different degrees of polishing, anti-abrasion treatments and modifications are available to adapt the valves to the customer's requirements.

### 2- SEAT

This type of valve has an elastic seat which is made up of a rubber seal located between the two parts of the body, secured with the screws used to join the two parts of the body. In valves DN50 to DN600 the seal has a metal core inserted in order to withstand the fluid pressure and allow the valve to shut off correctly (fig. 3).

600 las dos partes del cuerpo llevan un resalte exterior para impedir que la junta salga de su ubicación (fig. 4).

Este diseño de la junta proporciona un asiento completamente plano sin cavidades internas y evita la acumulación de sólidos en la zona del asiento de cierre.

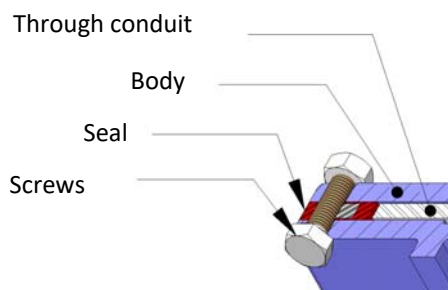

fig. 3

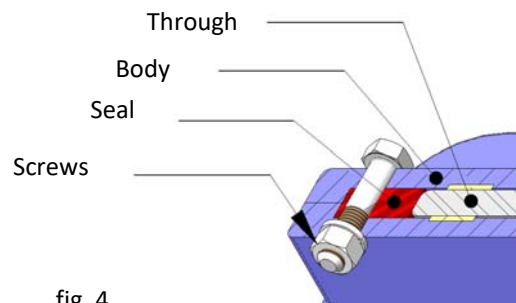

fig. 4

### Seal tight materials

**EPDM**

This is the standard resilient seal fitted on CMO valves. It can be used in many applications, however, it is generally used for water and products diluted in water at temperatures no higher than 90°C\*. It can also be used with abrasive products and provides the valve with 100% sealtightness.

**NITRILE**

Used in fluids containing fats or oils at temperatures no higher than 90°C\*. Provides the valve with 100% sealtightness.

**VITON**

Suitable for corrosive applications and high temperatures up to 190°C continuously and peaks of 210°C. Provides the valve with 100% sealtightness.

**SILICONE**

Mainly used in the food industry and for pharmaceutical products with temperatures no higher than 200°C. Provides the valve with sealtightness of 100%.

**PTFE**

Suitable for corrosive applications and pH between 2 and 12. Does not provide the valve with 100% sealtightness. Estimated leakage: 0.5% of the pipe flow.

**NotE:** In some applications other types of resilient materials are used, such as hypalon, butile or natural rubber. Please contact us if you require one of these materials.

**4- GASKET**

Las alves DN50 to DN600 not have the traditional gasket system, but rather a rubber strip inserted in the top of each body half. This system avoids the need to regularly replace the gasket and also offers the possibility of regulating the body from the outside by way of screws (fig. 5).

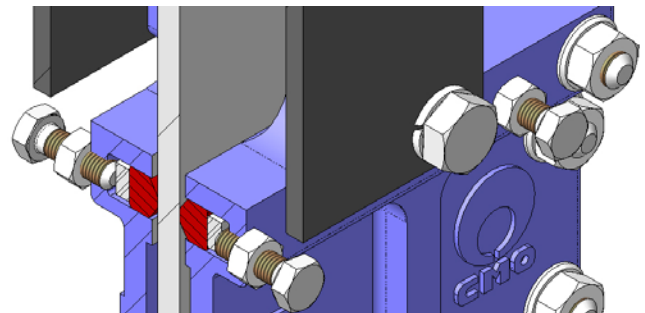

fig. 5

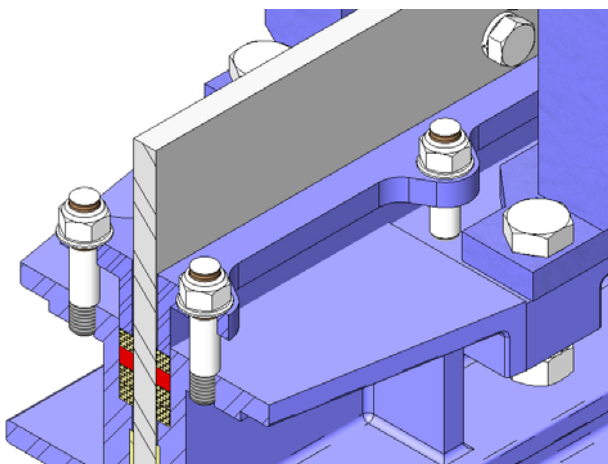

fig. 6

Valves over DN600 do have the traditional system and the standard CMO gasket comprises several lines (from 4 to 6 lines) of seal, providing the required sealtightness between the body and the through conduit and preventing any type of leakage. It is located in an easily accessible place and can be replaced without dismantling the valve from the pipeline (Fig 6).

Below we indicate various types of gasket available according to the use to be given to the valve:

**GREASED COTTON (Recommended for hydraulic services)**

This gasket is composed of braided cotton fibres soaked in grease both inside and out. It is for general use in hydraulic applications in both pumps and valves.

**DRY COTTON**

This gasket is composed of cotton fibres. It is for general use in hydraulic applications with solids.

**COTTON + PTFE**

This gasket is composed of braided cotton fibres soaked in PTFE both inside and out. It is for general use in hydraulic applications in both pumps and valves.

**SYNTHETIC + PTFE**

This gasket is composed of braided synthetic fibres soaked in PTFE both inside and out. It is for general use in hydraulic applications in both pumps and valves and in all types of fluids, especially corrosive ones, including concentrated and oxidising oils. It is also used in liquids with solid particles in suspension.

**LUBRICATED PTFE**

It is made with PTFE filaments and designed to work at great speed. It is braided with a diagonal system. Suitable for valves and pumps which work with almost all types of fluids, particularly with the most corrosive, such as oxidant and concentrated oils. It is also used in liquids with solid content.

**GRAPHITE**

This gasket is composed of high-purity graphite fibres. A diagonal braiding system is used and is impregnated with graphite and lubricant which helps to reduce porosity and improve operation.

It has a wide range of applications as graphite is resistant to steam, water, oils, solvents, alkali and most acids.

**CERAMIC FIBRE**

This gasket is composed of ceramic material fibres. Its main applications are with air or gas at high temperatures and low pressures.

SEAT / SEALS			GASKET			
Material	Máx.temp(°C)	Aplications	Material	P(bar)	Máx. temp (°C)	pH
EPDM (E)	90 *	Non-mineral oils, acids and water.	Greased cotton	10	100	6-8
Nitrile (N)	90 *	Hydrocarbons, oils and greases	Dry cotton (AS)	0,5	100	6-8
Viton (V)	200	Hydrocarbons and solvents	Cotton + PTFE	30	120	6-8
Silicone (S)	200	ood Products	Synthetic + PTFE	100	-200+270	0-14
PTFE (T)	250	Resistant to corrosion	Graphite	40	650	0-14
			Ceramic Fibre	0,3	1400	0-14

NOTE: More details and other materials available to order.

\*→ EPDM and Nitrile: possible up to Max temp: 120°C to order.

Table 2

**5- STEM**

The stem on the CMO valve is made of 18/8 stainless steel. This characteristic provides high resistance and excellent corrosion-resistant properties.

The standard valve design is with rising stem, although non-rising stem is also available. When a rising stem is required for the valve, a stem hood is supplied to protect the stem from contact with dust and dirt, besides keeping it lubricated.



## 6- PACKING GLAND

As mentioned above, valves DN50 to DN600 do not have the traditional packing system, but rather a stuffing box seal built into the body. Nevertheless, the common packing system is still used in sizes over DN600; this allows uniform pressure and force to be applied to the gasket, thus ensuring tightness.

As standard, valves with steel body include a steel packing gland flange, while for valves with stainless steel body this is made of stainless steel.

## 7- ACTUATORS

All types of actuators can be supplied, with the advantage that, thanks to the CMO design, they are fully interchangeable. This design allows customers to change the actuators themselves and no extra assembly accessories are required. A design characteristic of CMO valves is that all actuators are interchangeable.

### Manual:

Handwheel with non-rising stem  
 Handwheel with rising stem  
 Chainwheel  
 Lever  
 Gears  
 Others (square stem, etc)

### Automático:

Electric actuator  
 Pneumatic cylinder  
 Hydraulic cylinder

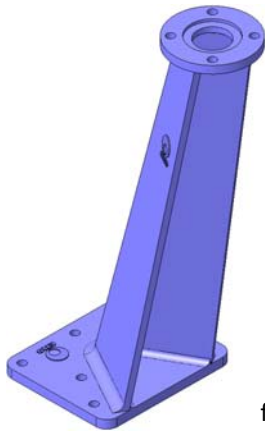

fig. 7

### Wide range of accessories available:

Mechanical stoppers  
 Locking devices  
 Emergency manual actuators  
 Electrovalves  
 Positioners  
 Limit switches  
 Proximity switches  
 Leaning floor stand (Fig. 7)  
 Straight floor stands (fig. 8)

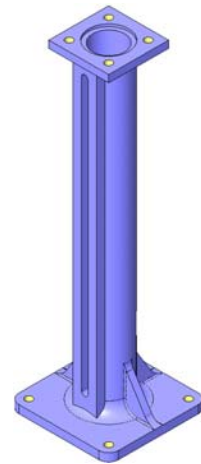

fig. 8

Stem extensions have also been developed, allowing the actuator to be located far away from the valve, to suit all needs. Please consult our technicians beforehand.

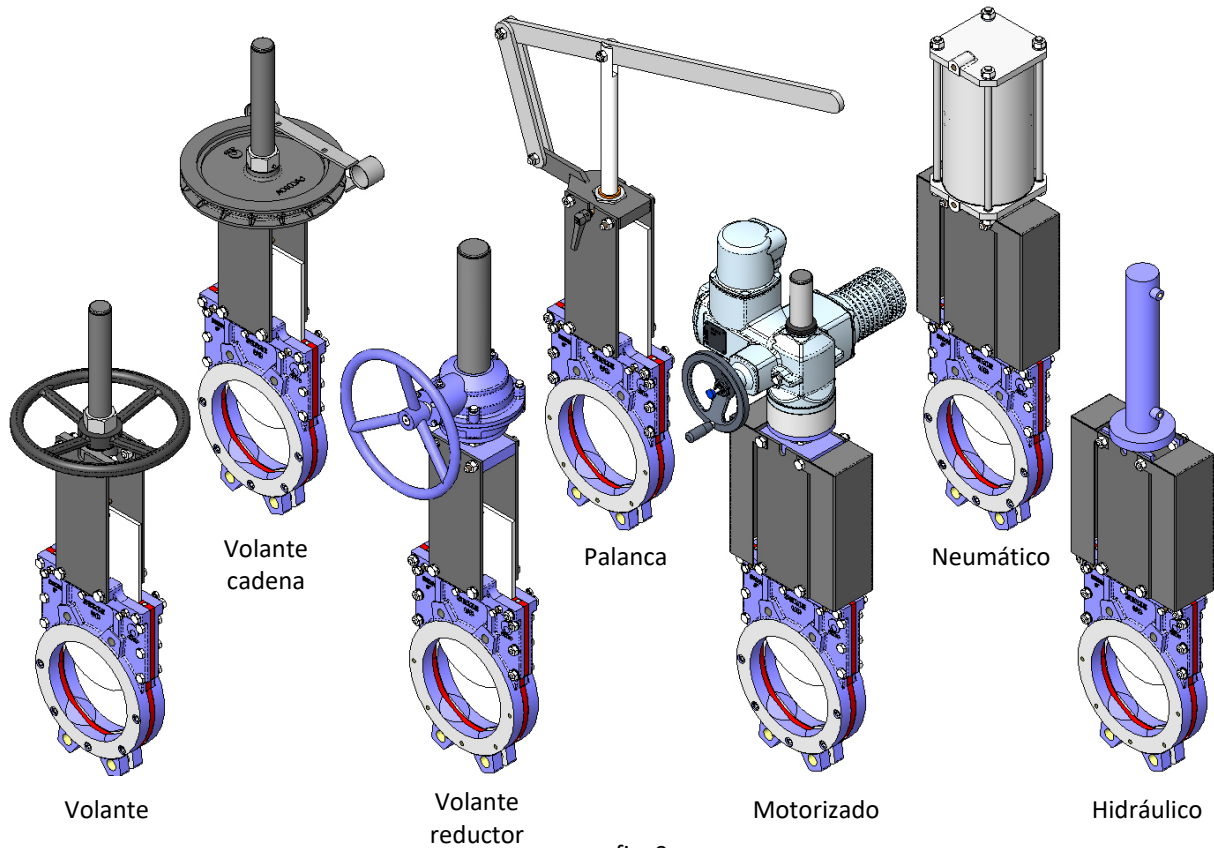

fig. 9

## ACCESSORIES AND OPTIONS

Different accessories are available to adapt the valve to specific working conditions such as:

**Mirror polished through conduit:**

The mirror polished through conduit is especially recommended in the food industry and, as standard, in applications in which solids can stick to the through conduit. It is an alternative to ensure the solids slide off and do not stick to the through conduit.

**PTFE lined through conduit:**

As with the mirror polished through conduit, it improves the valve's resistance to products that can stick to the through conduit.

**Stellited through conduit:**

Stellite is added to the through conduit's lower perimeter to protect it from abrasion.

**Scraper in the gasket:**

Its function is to clean the through conduit during the opening movement and prevent possible damage to the gasket.

**Air injections in the gasket:**

By injecting air in the gasket, an air chamber is created which improves sealtightness.

**Cased body:**

Recommended in applications in which the fluid can harden and solidify inside the valve's body. An external jacket keeps the body temperature constant, preventing the fluid from solidifying.

**Electrovalves (fig. 10):**

For air distribution to pneumatic actuators.

**Connection boxes, wiring and pneumatic piping:**

Units supplied fully assembled with all the necessary accessories.

**Mechanical limit switches, inductive sensors and positioners:**

Instalación de finales de carrera (fig. 10) o detectores para indicación de posición puntual de la válvula y posicionadores para indicación de posición continua.

**Mechanical locking device:**

Allows the valve to be mechanically locked in a set position for long periods

**Stroke limiting mechanical stops:**

Allow the stroke to be mechanically adjusted, limiting the valve run.

**Emergency manual actuator (hand wheel / gear box):**

Allows manual operation of the valve in the event of power or air failure (Fig 10).

**V-notch and pentagonal diaphragm with indication rule:**

Recommended for applications in which it is necessary to regulate the flow, it allows flow control according to the valve's opening percentage.

**Interchangeable actuators:**

All actuators are easily interchangeable.

**Actuator or yoke support:**

Made of EPOXY-coated steel (or stainless steel to order), its robust design gives it great rigidity in order to resist the most adverse operation conditions.

**Epoxy coating:**

All carbon steel or nodular cast-iron components and bodies of the CMO valves are EPOXY coated, giving the valves great resistance to corrosion and an excellent surface finish. CMO's standard colour is blue RAL-5015.

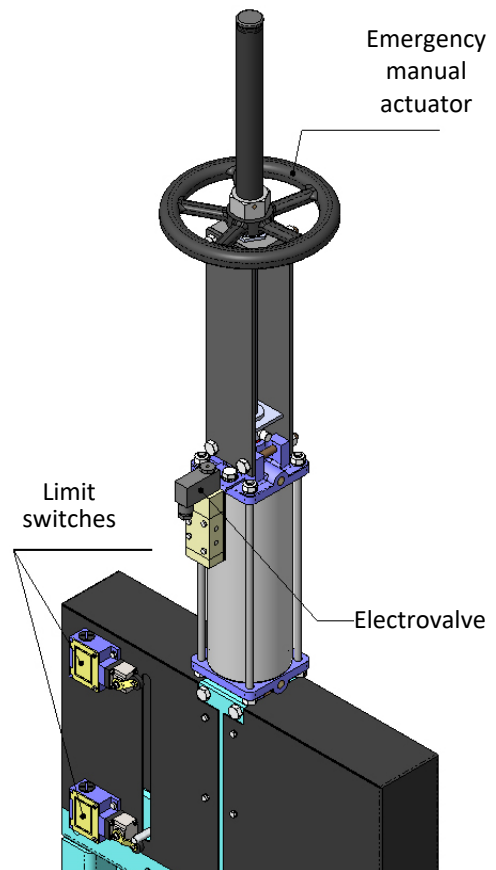

fig. 10



## TIPOS DE EXTENSIONES

When the valve needs to be operated from a distance, the following different types of actuators can be fitted:

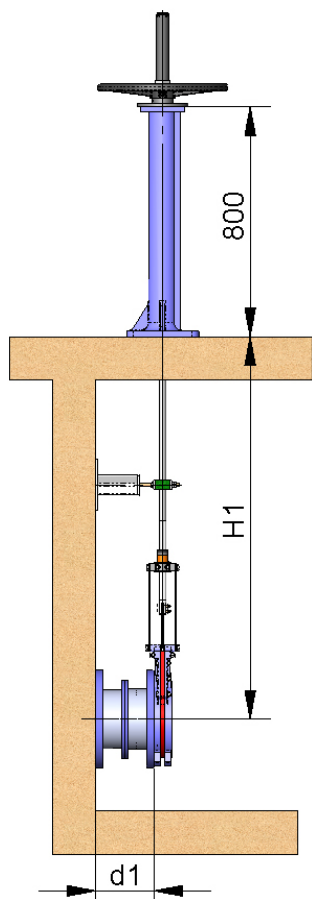

fig. 11

### 1- Extension: Floor Stand.

This extension is performed by coupling a spindle to the stem. By defining the length of the spindle, the desired extension is achieved. A floor stand is normally installed to support the actuator.

The definition variables are as follows:

**H1:** Distance from the valve shaft to the base of the stand.

**d1:** Separation from the wall to the end of the connecting flange.

### Characteristics:

It can be coupled to any type of actuator.

A stem support-guide is recommended (fig. 12) every 1.5 m.

The standard floor stand is 800 mm high (fig. 11). Other floor stand measurements available to order.

A position indicator can be fitted to determine the valve's percentage of opening.

Possibility of leaning floor stand (fig. 13).

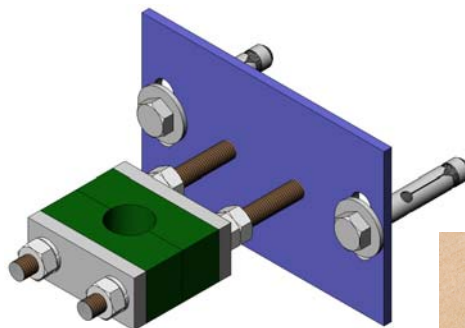

fig. 12

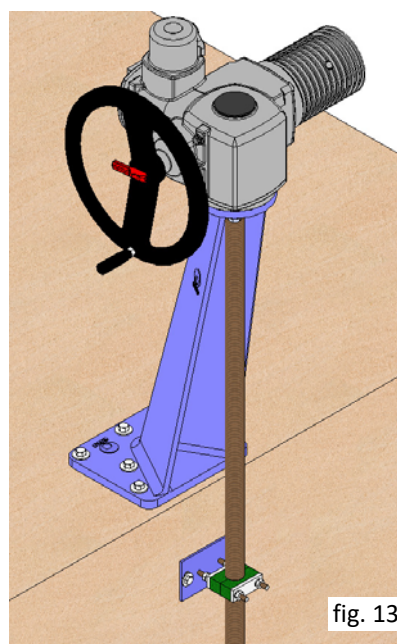

fig. 13

COMPONENTS LIST	
Component	Standard Version
Stem	AISI 303
Spindle	AISI 304
Guide-support	Carbon steel with EPOXI coating
Slide	Nylon
Floor Stand	GJS-500 with EPOXY coating

Table 3

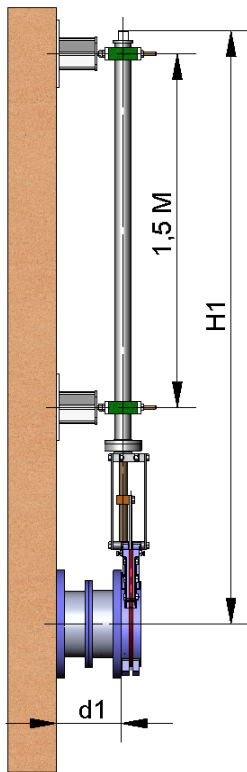

fig. 14

**2 - Extension: Pipe (fig. 14)**

Consists of raising the actuator. The pipe will rotate with the wheel or key when the valve is operated, although this will always remain at the same height.

The definition variables are as follows:

**H1:** Distance from the valve shaft to the required height of the actuator.

**d1:** Separation from the wall to the end of the connecting flange.

**Characteristics:**

Standard actuators: Handwheel and "Square Stem".

A pipe support-guide is recommended every 1.5m.

The standard materials are: EPOXY coated carbon steel or stainless steel.

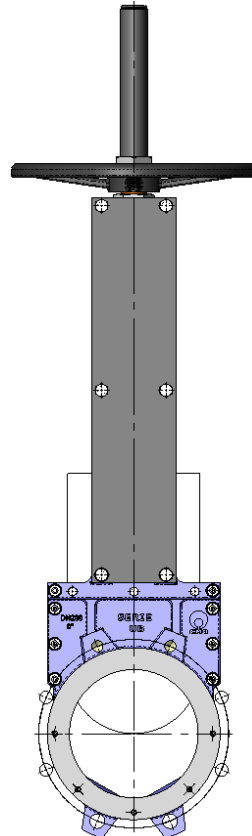

fig. 15

**3 - Extension: Extended Support Plates (fig. 15)**

When a short extension is required, it can be achieved by extending the support plates. An intermediate yoke can be fitted to reinforce the support plates structure.

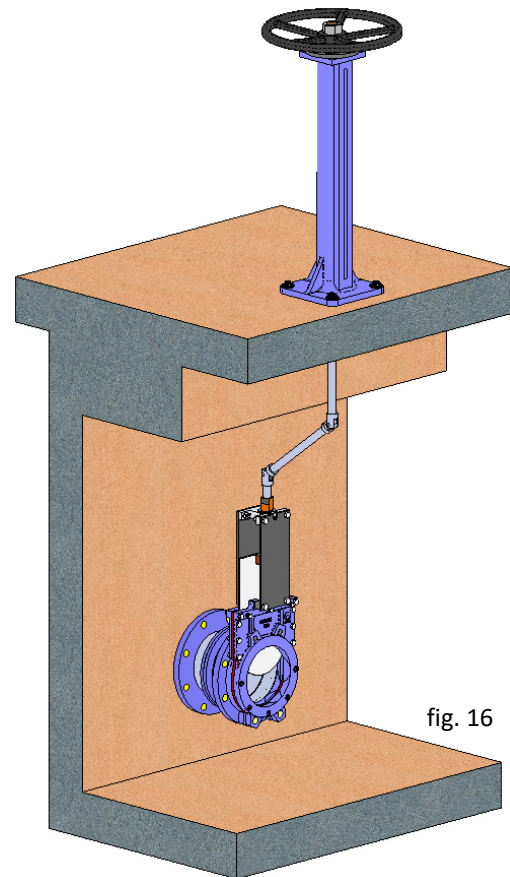

fig. 16

**4 - Extension: Cardan joint (fig. 16)**

If the valve and the actuator are not in correct alignment, the problem can be resolved by fitting a universal joint.

## HANDWHEEL

**B = max. width** of the valve (without actuator).

**D = max. height** of the valve (without actuator).

- Options:
  - Limiting switches.
  - Extensions: stand, pipe, plates,...
  - Square stem.
- Actuator comprising :
  - Handwheel.
  - Stem.
  - Nut.
- Available: DN50 to DN2000, other DN to order.
- From DN350 the actuator is with geared motor.

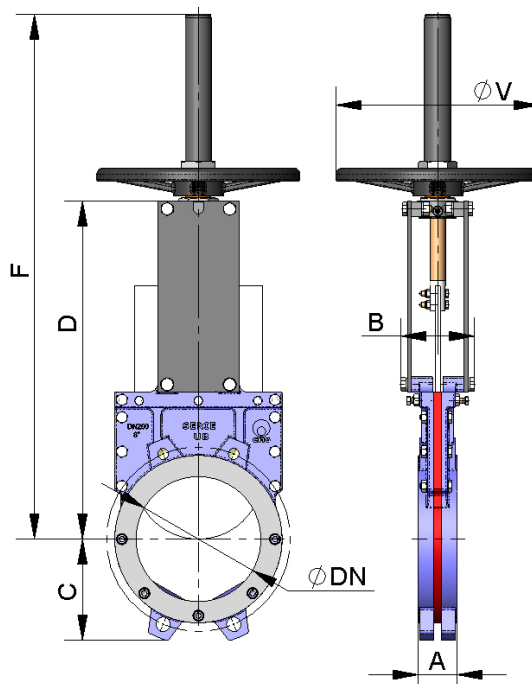

fig. 17

DN	$\Delta P$ (Kg/cm <sup>2</sup> )	DRAW (Nw)	TORQUE (Nm)	A	B	C	D	F	$\phi V$
50	10	1.177	2,7	43	90	66	245	418	225
65	10	1.987	4,5	46	90	73	270	443	225
80	10	3.009	7	46	90	96	295	468	225
100	10	4.700	11	52	90	110	327	500	225
125	10	7.342	17	56	100	123	365	588	225
150	10	10.576	24	56	100	136	415	638	225
200	10	18.816	43	60	118	162	541	840	325
250	7	20.615	47	68	118	199	630	1.029	325
300	7	29.729	85	78	118	225	745	1.149	450

Table 4

## HANDWHEEL - CHAIN

- Widely used in raised installations with difficult access, the handwheel is fitted in vertical position.
- **B = max. width** of the valve (without actuator)
- **D = max. height** of the valve (without actuator).
- Options:
  - Limiting switches.
  - Extensions: stand, pipe, plates,...
- Actuator comprising:
  - Handwheel.
  - Stem.
  - Nut.
- Available: DN50 to DN600, other DN to order.
- From DN350 the actuator is with gears, see \* in table.

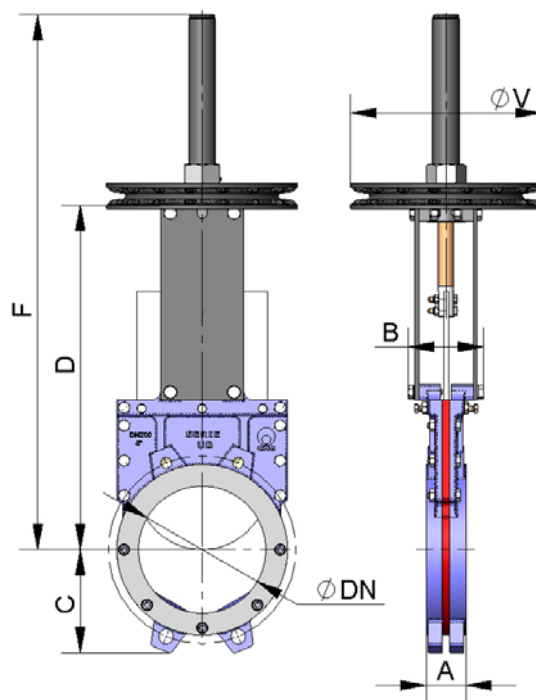

fig. 18

DN	$\Delta P$ (Kg/cm <sup>2</sup> )	DRAW (Nw)	TORQUE (Nm)	A	B	C	D	F	$\varnothing V$
50	10	1.177	2,7	43	90	66	245	418	225
65	10	1.987	4,5	46	90	73	270	443	225
80	10	3.009	7	46	90	96	295	468	225
100	10	4.700	11	52	90	110	327	500	225
125	10	7.342	17	56	100	123	365	588	225
150	10	10.576	24	56	100	136	415	638	225
200	10	18.816	43	60	118	162	541	840	300
250	7	20.615	47	68	118	199	630	1.029	300
300	7	29.729	85	78	118	225	745	1.149	402
350	6	34.777	99	78	218	257	869	1.414	300*
400	6	45.431	156	102	243	287	984	1.529	300*
450	4	38.522	132	114	254	318	1.117	1.815	300*
500	4	47.552	163	127	267	355	1.222	1.920	300*
600	4	68.722	266	154	294	418	1.442	2.140	402*

Table 5

## LEVER

- This is a fast actuator.
- **B = max. width** of the valve (without actuator).  
**B = max. height** of the valve (without actuator).
- The actuator includes:
  - Lever
  - Spindle.
  - Guide bushing.
- External limiting switches to maintain position.
- Available: DN50 to DN200, other DN to order.
- Actuator designed to run at 2 Kg/cm<sup>2</sup> of differential pressure (DP).

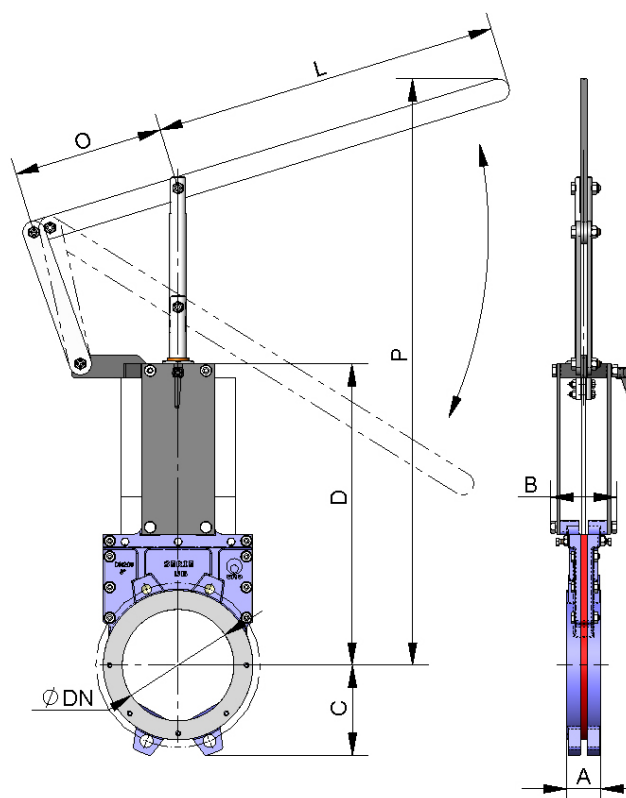

fig. 19

DN	$\Delta P$ (Kg/cm <sup>2</sup> )	DRAW (Nw)	A	B	C	D	L	O	P
50	10*	240*	43	90	66	245	325	140	518
65	10*	404*	46	90	73	270	325	140	543
80	10*	611*	46	90	96	295	325	140	568
100	10*	953*	52	90	110	327	325	140	600
125	10*	1.487*	56	100	123	365	325	140	832
150	10*	2.140*	56	100	136	415	325	140	882
200	10*	3.801*	60	118	162	541	620	270	1.052

Table 6



**GEAR BOX**

- This is recommended from DN 350.
- **B = max. width** of the valve (without actuator).
- **B = max. height** of the valve (without actuator).

Options:

- ChainWheel
- Limiting switches.
- Extensions: stand, pipe, plates,...

Actuator comprising:

- Steam.
- Yoke.
- Cone-shaped gear box.
- Handwheel.

- Standard reduction ratio = 4 to 1.
- Available: DN 50 to DN 2000, other DN to order.

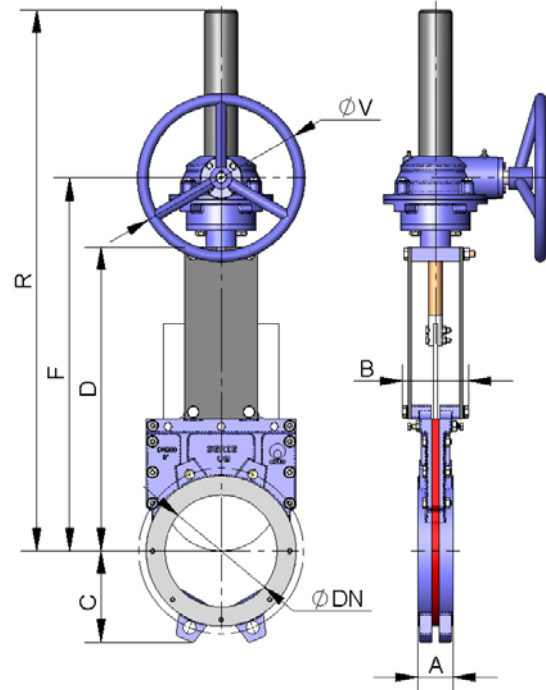
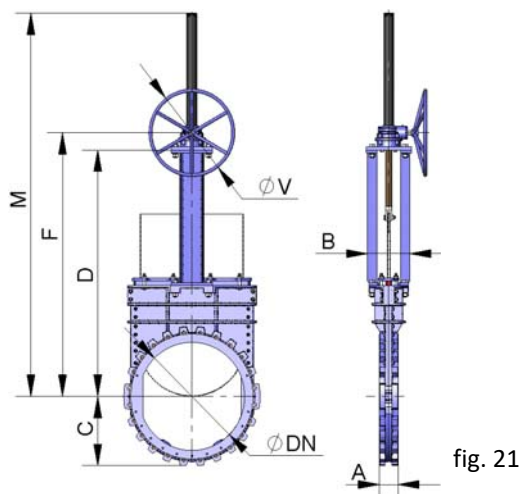

fig. 20

DN	$\Delta P$ (Kg/cm <sup>2</sup> )	DRAW (Nw)	TORQUE (Nm)	A	B	C	D	F	R	$\phi V$
50	10	1.177	2,7	43	90	66	245	369	548	300
65	10	1.987	4,5	46	90	73	270	394	573	300
80	10	3.009	7	46	90	96	295	419	598	300
100	10	4.700	11	52	90	110	327	451	630	300
125	10	7.342	17	56	100	123	365	489	668	300
150	10	10.576	24	56	100	136	415	539	718	300
200	10	18.816	43	60	118	162	541	665	964	300
250	7	20.615	47	68	118	199	630	754	1.053	300
300	7	29.729	85	78	118	225	745	869	1.168	300
350	6	34.777	99	78	218	257	869	965	1.414	300
400	6	45.431	156	102	243	287	984	1.080	1.529	300
450	4	38.522	132	114	254	318	1.117	1.216	1.815	300
500	4	47.552	163	127	267	355	1.222	1.321	1.920	300
600	4	68.722	266	154	294	418	1.442	1.559	2.140	450

Table 7



DN	$\Delta P$ (Kg/cm <sup>2</sup> )	DRAW (Nw)	TORQUE (Nm)	A	B	C	D	F	R	$\phi V$
700	2	47.294	259	140	320	446	1.548	1.650	2.391	450
	4	94.159	514					1.650	2.403	1.000
	6	140.604	768					1.784	2.441	450
	10	233.036	1.512					1.784	2.441	850
800	2	62.212	340	140	320	513	1.823	1.929	2.783	650
	4	122.952	672					2.059	2.816	300
	6	183.709	1.192					2.059	2.816	650
	10	305.146	2.291					2.097	2.866	1.000
900	2	79.697	436	140	320	585	2.059	2.161	3.114	850
	4	156.580	1.016					2.295	3.152	450
	6	233.356	1.514					2.295	3.152	850
	10	386.285	3.247					2.333	3.202	1.350
1.000	2	98.361	538	145	320	614	2.190	2.426	3.383	300
	4	193.264	1.254					2.426	3.383	650
	6	288.189	2.164					2.464	3.433	1.000
	10	478.102	4.565					2.482	3.448	1.350
1.200	2	143.304	930	150	350	726	2.616	2.852	4.009	450
	4	279.961	2.102					2.890	4.059	1.350
	6	416.644	3.502					2.890	4.059	1.350
	10	691.675	7.225					3.041	4.261	1.350
1.400	2	195.156	1.465	160	350	837	2.990	3.264	4.633	650
	4	383.320	3.222					3.264	4.633	850
	6	571.797	5.973					3.474	4.894	1.350
	10	944.011	11.788					3.510	4.930	1.350
1.600	2	257.855	2.167	170	390	960	3.480	3.754	5.323	850
	4	503.617	4.809					4.772	5.338	1.000
	6	749.771	8.506					4.168	5.788	1.350
1.800	2	329.766	2.772	180	440	1.060	3.983	4.257	6.026	850
	4	641.131	6.697					4.488	6.308	1.350
	6	952.649	11.896					4.488	6.308	1.350
2.000	2	407.327	3.889	190	480	1.165	4.390	4.682	6.648	1.350
	4	796.627	9.947					4.788	6.808	1.350
	6	1.180.709	15.804					4.788	6.808	1.350

Table 8

## DOUBLE-ACTING PNEUMATIC CYLINDER

- The air supply pressure to the pneumatic cylinder is a minimum of 6 Kg/cm<sup>2</sup> and a maximum of 10 Kg/cm<sup>2</sup>, the air must be dry and lubricated.
  - 10 Kg/cm<sup>2</sup> is the maximum admissible air pressure. For air pressures below 6 Kg/cm<sup>2</sup>, please check with **C.M.O.**
  - For DN50 to DN150 valves, the cylinder's jacket and covers are made of aluminium, the spindle in AISI304, the piston of rubber-coated steel and the O-ring seals are made of nitrile.
  - For valves over DN150 the covers are made of nodular cast iron or carbon steel.
- To order, we can also supply the actuator made entirely of stainless steel, especially for installation in corrosive atmospheres.
- **B = max. width** of the valve (without actuator).
  - **D = max. height** of the valve (without actuator).
- Available: DN50 to DN600, other DN to order.

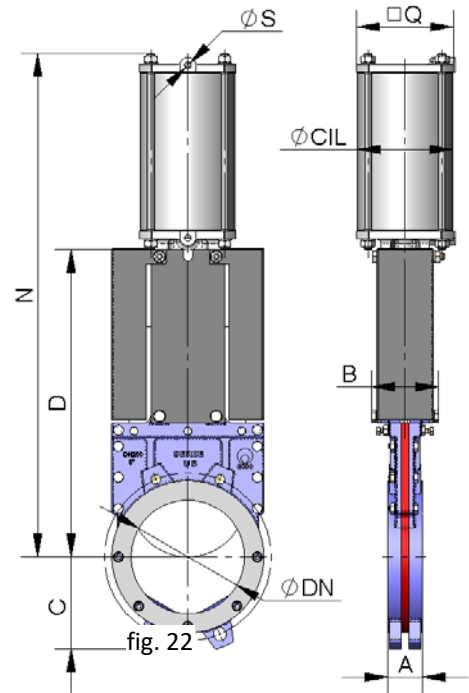

DN	$\Delta P$ (Kg/cm <sup>2</sup> )	DRAW (Nw)	A	B	C	D	N	Q	$\varnothing$ CIL	$\varnothing$ VAST	S (B.S.P)
50	10	1.177	43	90	66	245	420	90	80	20	1/4"
65	10	1.987	46	90	73	270	460	90	80	20	1/4"
80	10	3.009	46	90	96	295	500	90	80	20	1/4"
100	10	4.700	52	90	110	327	553	110	100	20	1/4"
125	10	7.342	56	100	123	365	632	135	125	25	1/4"
150	10	10.576	56	100	136	415	706	135	125	25	1/4"
200	10	18.816	60	118	162	541	886	170	160	30	1/4"
250	7	20.615	68	118	199	630	1.037	215	200	30	3/8"
300	7	29.729	78	118	225	745	1.202	215	200	30	3/8"
350	6	34.777	78	218	257	869	1.454	270	250	40	3/8"
400	6	45.431	102	243	287	984	1.619	270	250	40	3/8"
450	4	38.522	114	254	318	1.117	1.815	336	300	45	1/2"
500	4	47.552	127	267	355	1.222	1.970	336	300	45	1/2"
600	4	68.722	154	294	418	1.442	2.290	336	300	45	1/2"

Table 9

**ELECTRIC ACTUATOR**

- This actuator is automatic and includes the following parts:
  - Electric motor.
  - Stem.
  - Yoke.
- The electric motor includes:
  - Emergency manual handwheel.
  - Limit switches.
  - Torque limiters.
- Choice of different types and brands.
- ISO 5210 / DIN 3338 Flanges.
- Available: DN50 to DN 2000, other DN to order.
- From DN300 the motor is assisted with a gear box, see \* in table.

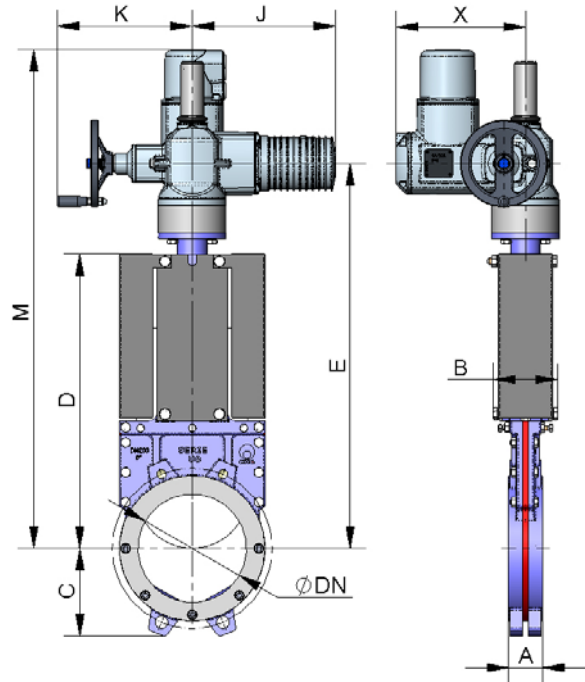
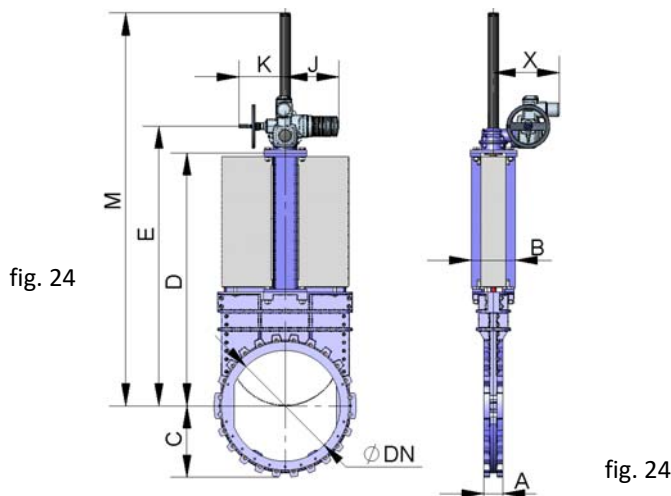

fig. 23

DN	$\Delta P$ (Kg/cm <sup>2</sup> )	DRAW (Nw)	PAR (Nm)	A	B	C	D	E	J	K	M	X
50	10	1.177	2,7	43	90	66	245	413	264	249	623	237
65	10	1.987	4,5	46	90	73	270	438	264	249	648	237
80	10	3.009	7	46	90	96	295	463	264	249	673	237
100	10	4.700	11	52	90	110	327	495	264	249	705	237
125	10	7.342	17	56	100	123	365	533	264	249	743	237
150	10	10.576	24	56	100	136	415	583	264	249	793	237
200	10	18.816	43	60	118	162	541	709	264	249	919	237
250	7	20.615	47	68	118	199	630	798	264	249	1.086	237
300	7	29.729	85	78	118	225	745	915	264	249	1.209	422*
350	6	34.777	99	78	218	257	869	1.005	264	249	1.414	422*
400	6	45.431	156	102	243	287	984	1.120	264	249	1.529	422*
450	4	38.522	132	114	254	318	1.117	1.266	264	249	1.815	422*
500	4	47.552	163	127	267	355	1.222	1.371	283	254	1.920	422*
600	4	68.722	266	154	294	418	1.442	1.590	283	254	2.140	424*

Table 10



DN	$\Delta P$ (Kg/cm <sup>2</sup> )	TIRO (Nw)	PAR (Nm)	A	B	C	D	E	J	K	M	X
700	2	47.294	259	140	320	446	1.548	1.700	283	254	2.391	453
	4	94.159	514					1.717	389	336	2.403	479
	6	140.604	768					1.834	283	254	2.441	583
	10	233.036	1.512					1.851	389	336	2.441	609
800	2	62.212	340	140	320	513	1.823	1.976	283	254	2.783	453
	4	122.952	672					1.992	389	336	2.816	479
	6	183.709	1.192					2.109	283	254	2.816	583
	10	305.146	2.291					2.164	389	336	2.866	638
900	2	79.697	436	140	320	585	2.059	2.228	389	336	3.114	479
	4	156.580	1.016					2.245	283	254	3.152	583
	6	233.356	1.514					2.362	389	336	3.152	609
	10	386.285	3.247					2.418	389	336	3.202	706
1.000	2	98.361	538	145	320	614	2.190	2.359	389	336	3.383	479
	4	193.264	1.254					2.476	283	254	3.383	583
	6	288.189	2.164					2.531	389	336	3.433	638
	10	478.102	4.565					2.419	389	336	3.577	638
1.200	2	143.304	930	150	350	726	2.616	2.902	283	254	4.009	583
	4	279.961	2.102					2.957	389	336	4.059	638
	6	416.644	3.502					2.860	389	336	4.218	653
	10	691.675	7.225					2.878	389	339	4.218	721
1.400	2	195.156	1.465	160	350	837	2.990	3.331	389	336	4.633	638
	4	383.320	3.222					3.365	389	336	4.923	638
	6	571.797	5.973					3.347	389	339	4.947	721
	10	944.011	11.788					3.347	389	339	4.947	721
1.600	2	257.855	2.167	170	390	960	3.480	3.821	389	336	5.323	638
	4	503.617	4.809					4.023	389	336	5.781	638
	6	749.771	8.506					4.005	389	339	5.805	721
1.800	2	329.766	2.772	180	440	1.060	3.983	4.374	389	336	6.026	706
	4	641.131	6.697					4.361	389	336	6.319	853
	6	952.649	11.896					4.361	389	336	6.319	853
2.000	2	407.327	3.889	190	480	1.165	4.390	4.781	389	336	6.648	706
	4	796.627	9.947					4.661	389	336	6.861	853
	6	1.180.709	15.804					4.661	389	336	6.861	853

Table 11



**HYDRAULIC ACTUATOR (Oil pressure: 135 Kg/cm<sup>2</sup>)**

- **B = max. width** of the valve (without actuator).
- **D = max. height** of the valve (without actuator).
- The hydraulic actuator includes:
  - Hydraulic cylinder.
  - Yoke.
- Available: DN50 to DN 2000, other DN to order.
- Different types and brands available according to customer's requirements.

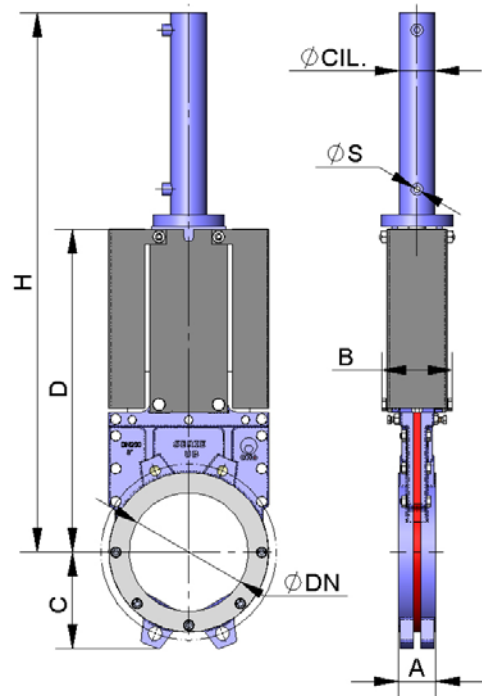

fig. 25

DN	ΔP (Kg/cm <sup>2</sup> )	DRAW (Nw)	A	B	C	D	H	Ø CIL.	Ø VAST	S (B.S.P.)	Cap. Aceite (dm)
50	10	1.177	43	90	66	245	424	25	18	3/8"	0,032
65	10	1.987	46	90	73	270	479	25	18	3/8"	0,047
80	10	3.009	46	90	96	295	504	25	18	3/8"	0,047
100	10	4.700	52	90	110	327	556	32	22	3/8"	0,092
125	10	7.342	56	100	123	365	624	32	22	3/8"	0,117
150	10	10.576	56	100	136	415	719	40	28	3/8"	0,214
200	10	18.816	60	118	162	541	904	50	28	3/8"	0,436
250	7	20.615	68	118	199	630	1.043	50	28	3/8"	0,534
300	7	29.729	78	118	225	745	1.213	50	28	3/8"	0,632
350	6	34.777	78	218	257	869	1.400	63	36	3/8"	1,153
400	6	45.431	102	243	287	984	1.565	63	36	3/8"	1,309
450	4	38.522	114	254	318	1.117	1.770	80	36	3/8"	2,362
500	4	47.552	127	267	355	1.222	1.935	80	36	3/8"	2,614
600	4	68.722	154	294	418	1.442	2.255	80	36	3/8"	3,116

Table 12

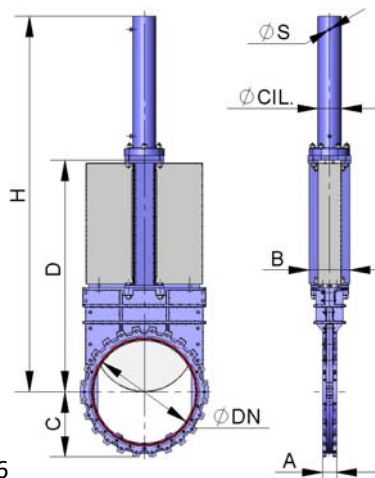

fig. 26

DN	$\Delta P$ (Kg/cm <sup>2</sup> )	TIRO (Nw)	A	B	C	D	H	Ø CIL.	Ø VAST.	S (B.S.P.)	Cap. Aceite (dm)
700	2	47.294	140	320	446	1.548	2.432	100	45	1/2"	5,69
	4	94.159					2.447	125	56	1/2"	8,90
	6	140.604					2.476	140	56	1/2"	11,16
	10	233.036					2.541	200	90	1/2"	22,78
800	2	62.212	140	320	513	1.823	2.726	100	45	1/2"	6,48
	4	122.952					2.770	140	56	1/2"	12,70
	6	183.709					2.793	160	70	1/2"	16,59
	10	305.146					2.835	200	90	1/2"	25,92
900	2	79.697	140	320	585	2.059	3.078	125	56	1/2"	11,35
	4	156.580					3.107	140	56	1/2"	14,24
	6	233.356					3.172	200	90	1/2"	29,06
	10	386.285					3.190	220	90	1/2"	35,16
1.000	2	98.361	145	320	614	2.190	3.459	125	56	1/2"	12,64
	4	193.264					3.511	160	70	1/2"	20,71
	6	288.189					3.553	200	90	1/2"	32,36
	10	478.102					3.594	250	90	1/2"	50,56
1.200	2	143.304	150	350	726	2.616	4.188	160	70	1/2"	24,73
	4	279.961					4.230	200	90	1/2"	38,64
	6	416.644					4.271	250	90	1/2"	60,38
	10	691.675					4.305	320	110	1/2"	98,92
1.400	2	195.156	160	350	837	2.990	4.855	160	70	1/2"	28,75
	4	383.320					4.917	220	90	1/2"	54,36
	6	571.797					4.972	320	110	1/2"	115,01
	10	944.011					5.010	350	110	1/2"	137,58
1.600	2	257.855	170	390	960	3.480	5.765	200	90	1/2"	51,21
	4	503.617					5.807	250	90	1/2"	80,01
	6	749.771					5.900	320	110	1/2"	131,09
1.800	2	329.766	180	440	1.060	3.983	6.470	220	90	1/2"	69,56
	4	641.131					6.585	320	110	1/2"	147,18
	6	952.649					6.625	350	110	1/2"	182,8
2.000	2	407.327	190	480	1.165	4.390	6.992	250	90	1/2"	99,89
	4	796.627					7.085	320	110	1/2"	147,18
	6	1.180.709					7.150	350	110	1/2"	202,04

Table 13

INFORMATION ON FLANGE DIMENSIONS

EN 1092-2 PN10

DN	ΔP (Kg/cm <sup>2</sup> )		Qty.		Metric	P	ØK
			●	○			
50	10		2	2	M 16	9	125
65	10		2	2	M 16	9	145
80	10		2	6	M 16	11	160
100	10		2	6	M 16	12	180
125	10		2	6	M 16	12	210
150	10		2	6	M 20	14	240
200	10		2	6	M 20	14	295
250	10		4	8	M 20	14	350
300	7	10	4	8	M 20	14	400
350	7	10	6	10	M 20	20	460
400	6	10	6	10	M 24	21	515
450	6	10	8	12	M 24	22	565
500	4	10	8	12	M 24	22	620
600	4	10	8	12	M 27	22	725
700	2	4	6	10	M 27	23	840
800	2	4	6	10	M 30	23	950
900	2	4	6	10	M 30	23	1.050
1.000	2	4	6	10	M 33	23	1.160
1.200	2	4	6	10	M 36	30	1.380
1.400	2	4	6	10	M 39	30	1.590
1.600	2	4	6	6	M 45	35	1.820
1.800	2	4	6	4	M 45	35	2.020
2.000	2	4	6	4	M 45	40	2.230

ANSI B16, class 150 Table 14

DN	ΔP (Kg/cm <sup>2</sup> )		Cant.		R UNC	P	ØK
			●	○			
2"	10		2	2	5/8"	9	120,6
2 ½"	10		2	2	5/8"	9	139,7
3"	10		2	2	5/8"	11	152,4
4"	10		2	6	5/8"	12	190,5
5"	10		2	6	3/4"	12	215,9
6"	10		2	6	3/4"	14	241,3
8"	10		2	6	3/4"	14	298,4
10"	10		4	8	7/8"	14	361,9
12"	7	10	4	8	7/8"	14	431,8
14"	7	10	4	8	1"	20	476,2
16"	6	10	6	10	1"	21	539,7
18"	6	10	6	10	1 ½"	22	577,8
20"	4	10	8	12	1 ½"	22	635
24"	4	10	8	12	1 ¼"	22	749,3
28"	2	4	6	10	1 ¼"	23	863,6
32"	2	4	6	10	1 ½"	23	977,9
36"	2	4	6	10	1 ½"	23	1.085,9
40"	2	4	6	10	1 ½"	23	1.200,2
48"	2	4	6	10	1 ½"	30	1.422,4
56"	2	4	6	10	1 ¾"	30	1.651

Table 15

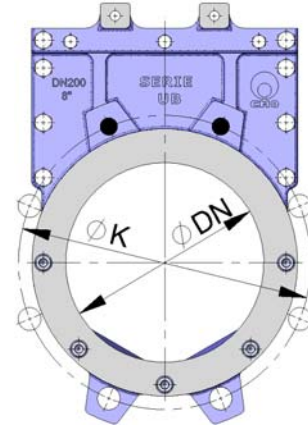

DN50 - 600  
fig. 27

- BLIND TAPPED HOLE
- THROUGH HOLE

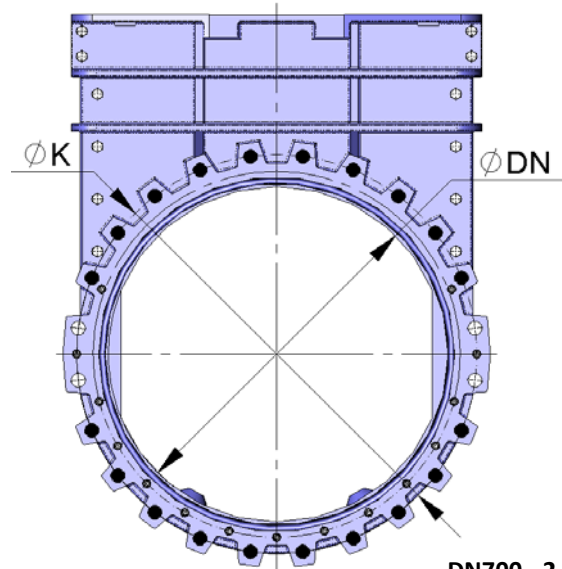

DN700 - 2.000  
fig. 28

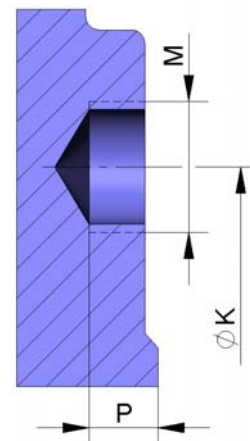

fig. 29

SERIES

UB



GESTION DE  
LA CALIDAD  
CERTIFICADA

QUALITY  
MANAGEMENT  
CERTIFIED



**CMO VALVES**  
manufacturing the valve you need



**CMO VALVES - CONSTRUCCIONES METÁLICAS DE OBTURACION**

Amategui Aldea 142, 20400 Txarama-Tolosa (SPAIN)

Tel.: 34.943.67.33.99

[cmo@cmovalves.com](mailto:cmo@cmovalves.com) [www.cmovalves.com](http://www.cmovalves.com)